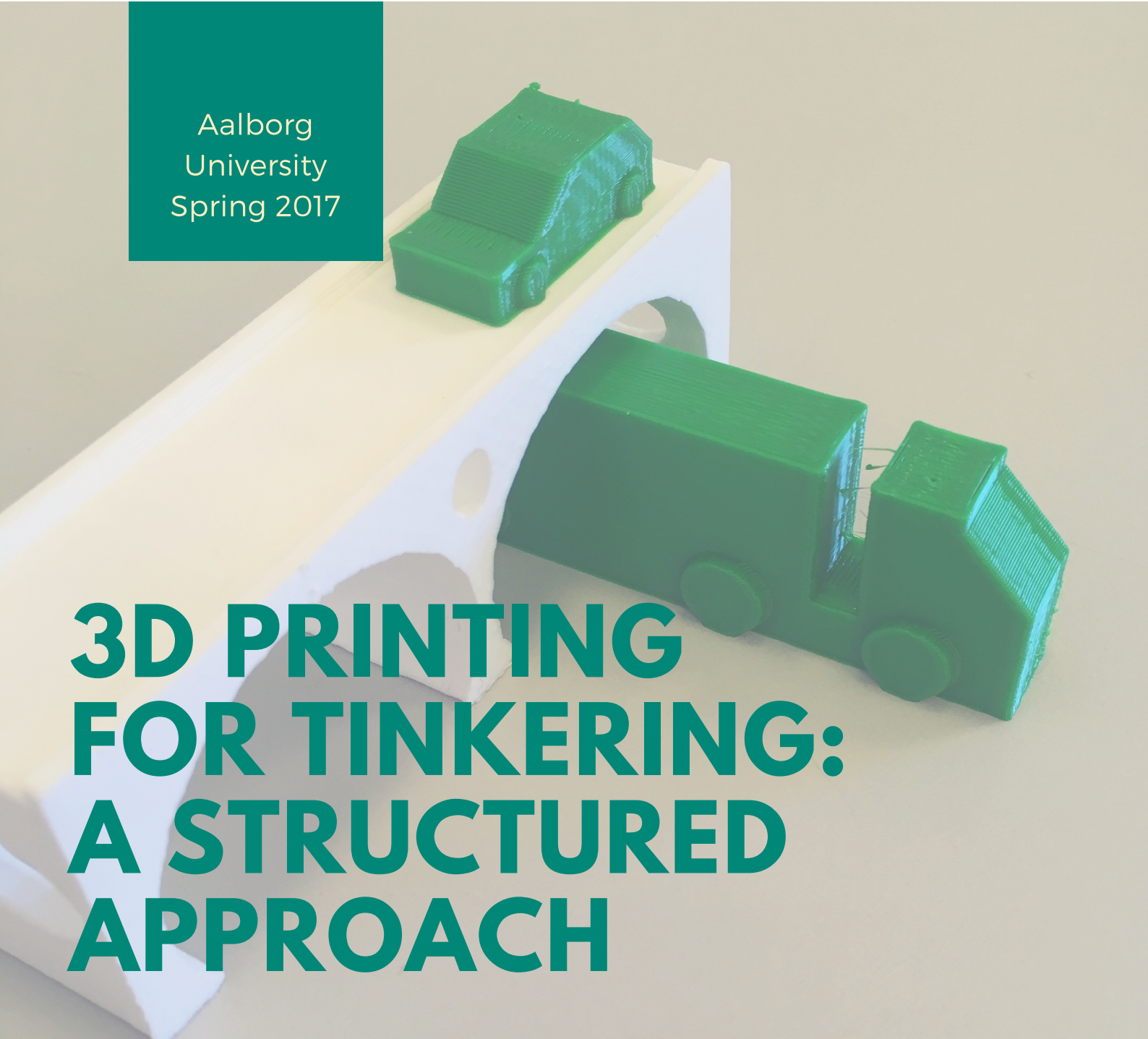

Aalborg
University
Spring 2017

A photograph of a white spirit level with two green 3D printed truck models. One truck is positioned on top of the level, while the other is placed on the surface next to it. The background is a plain, light-colored surface.

3D PRINTING FOR TINKERING: A STRUCTURED APPROACH

A qualitative study on how to achieve a tinkering mindset, when working with STEM fields, and developing 21st century skills in Danish Middle schools

Anders Bod Lund
Helga Negendahl

**4th semester
Engineering Psychology Master's Programme**



AALBORG UNIVERSITY

STUDENT REPORT

Institut for Elektroniske Systemer

Fredrik Bajers Vej 7

DK-9220 Aalborg Ø

<http://es.aau.dk>

Title:

3D Printing for Tinkering:
A Structured Approach

Theme:

Master's Thesis

Project Period:

Spring semester 2017

Project Group:

15gr1087

Participant(s):

Anders Bod Lund
Helga Negendahl Madsen

Supervisor(s):

Dorte Hammershøi
Thomas Ryberg

Copies: 5

Page Numbers: 158

Date of Completion:

8. June 2017

Abstract:

In this study, the learning potentials and barriers when introducing 3D printers in Danish Middle Schools, are investigated. The project group collaborated with Create it REAL and the Municipality of Aalborg. First an exploratory Pilot Study was conducted, to investigate how four Danish Middle schools included 3D printing into their classes. The Pilot Study included data from three sources: Interviews with teachers, observations of learning activities, and questionnaires. The findings from the Pilot Study were used to create a proposal for an approach to learning activities with 3D printers dubbed the Oresmian Coordinate System. This approach was created to encourage: tinkering, learning of 21st century skills, and reflective exploration of STEM fields.

This approach was tested through a Field Study, and through observations as well as a video review session, indications were found that this approach can support a rich collaborative learning environment, and support the teacher in having reflective discussions with pupils regarding designs and iterations.

Foreword

This project is a combination of Anders' passion of using 3D printers as a tool in education and Helgas love for creative methods and innovation. The project period extends from the 1st of February 2017 to the 8th of June 2017. However, some data was gathered during Anders' internship before this period, but the data was not organized or analysed until the official semester start. Furthermore, we also facilitated additional workshops during the autumn of 2016, although no data was gathered from these. To get an overview of these workshops and when the different sources of data were collected see E. All data within this project in which audio visual representations of children are present has been obtained with the written consent of the children's parents or guardians. Due to the sensitive nature of the data it is not included in the appendices in its raw form. However, transcribed records are included, and in these pupils and teachers are given aliases to maintain their anonymity. The following is our thesis for our master's programme in the "Engineering Psychology Programme" at Aalborg University. We have documented our work in this report and in our article which we will presenting at the EDULEARN conference the 3-5. of July 2017. Furthermore, the article will be published in the conference proceedings. The article is also included in Appendix A.

By signing this document the authors state that they have both participate in the project work, and that they share equal responsibility.



Anders Bod Lund



Helga Negendahl Madsen

Reading Guide In this report sources will be cited using the Harvard Method, an example being [Blikstein, 2013a]. Figures and tables will be referred to by numbers as such: table 3.3, figure 4.2. Sections and chapters will be referenced by a number: (see 5.1.2), and appendices by a letter: (see Appendix F).

Acknowledgements We would like to thank Jeremie Pierre Gay, founder and CEO of Create it REAL, and Thomas Overgaard, business playmaker at the Municipality of Aalborg, for initiating this project, and for your collaboration during the study. We would also like to thank the entire Create it REAL team for always working hard to improve their technology and providing swift solutions for technical issues. Furthermore, we would like to thank Ian Rubeck Stenz from Friskolen Skallerup for envisioning the idea of designing, printing, and testing bridges - an idea that was built heavily upon in this study. Finally, we would like to thank all the teachers from Højvang, Vadum, Sønderbro, and Hals who have been a part of the project – thank you for going above and beyond in your quest to adopt interesting technologies in your classrooms amidst your busy schedules.

Danish Summery

I dette studie vil brugen af 3D printere på fire Danske folkeskoler blive undersøgt. Studiet er en del af et samarbejde mellem Aalborg Kommune og den Nordjyske virksomhed Create it REAL. Projektet startede i efteråret 2016 hvor de fire skoler modtog deres 3D printere. De deltagende skoler var: Hals Skole, Vadum Skole, Højvang Skolen, og Sønderbro Skolen. Alle skolerne fik en 3D printer af mærket Weistek Ideawerk Speed, som er udviklet til undervisningsbrug og har den fordel at den printer relativt hurtigt. Empirien til studiet er indsamlet i to overordnede dele, et eksplorativt pilotstudie, og et bekræftende feltstudie, i begge disse studier er der brugt kvalitative metoder til indsamling og analysering af data. Under pilotstudiet blev der indsamlet data fra tre forskellige kilder: Feltnoter fra observationer, Interviews med de involverede lærere samt et spørgeskema som blev delt ud til de deltagende elever. Interviewene var semistrukturerede og blev afholdt med den af lærerne på hver skole som havde ansvaret for at undervise med 3D printeren. Spørgsmålene omhandlede deres erfaringer og metoder til at planlægge undervisningen med en 3D printer, herunder hvilke udfordringer de havde oplevet og hvilke muligheder de så for at inddrage 3D printeren i deres fremtidige undervisning. Spørgeskemaet til eleverne bestod af seks spørgsmål, som var "open ended", dette for at danne et billede af hvordan eleverne havde oplevet undervisningen. Spørgeskemaet blev uddelt i forbindelse med en dag hvor alle eleverne fra de forskellige skoler skulle mødes til en workshop. Der blev lavet to observationer, én på Vadum Skole og en længere på Hals Skole.

Data der var indsamlet fra pilotstudiet blev analyseret separat med en fem-faset kvalitativ metode lavet af Robert Yin. I denne metode findes der mønstre på tværs af data som som der bliver fortolket på. I pilotstudiet bliver der derfor lavet en analyse af data fra interviews, spørgeskema og observationer. Efterfølgende er der lavet en diskussion hvor de elementer som går igen i alle tre analyser bliver diskuteret. Alle skolerne har modtaget én eller to 3D printere i forbindelse med deres deltagelse i projektet mellem Aalborg kommune og Create it REAL. Alle tre analyser viser tydelige tegn på at dette ikke er nok. Lærerne underviser 12-20 elever og kan ikke nå at få 3D printet alle de designs som eleverne producerer, og må derfor ofte bruge deres forberedelsestid på dette. Dette gør at eleverne mister motivationen for at fortsætte deres arbejde, blandt andet fordi de ikke har nogen kontrol over processen. Alle analyserne viser også at det objekt som eleverne designer har en betydning. Lærerne lader eleverne lave designs som er personlige for at motiverer dem. Vi stiller dog spørgsmålstegn om det at designe personlige objekter er godt for et undervisningsmæssigt udbytte. Blandt andet blev det observeret at selv om eleverne på Hals Skole skulle arbejde sammen om at designe smartphone covers som de kunne sælge, ville de hellere arbejde alene og designe et til dem selv. Dette kan kategoriseret som et tegn på "Nøglerings syndromet" hvor elever designe små fine objekter til brug, men som ikke nødvendigvis medføre så meget læring. Gennem analyserne er der også vist noget om hvilket læringspotentiale det har at inddrage en 3D printer i en undervisningssituation. Her ses det at 3D printeren passer godt ind i STEM fag samt problembaseret læring, men at lærerne, især grundet kapacitetsproblemer, ikke helt har formået at få læringen op på dette niveau. Lærerne

efterspørger værktøjer som de kan bruge til undervisningen med en 3D printer.

Med den viden blev der afholdt en kreativ process, hvor der blev generede ideer som skulle hjælpe med at få introduceret 3D printeren i en undervisningen. Én af ideerne var at bruge et koordinatsystem i undervisningen, denne blev kaldt "The Oresmain Coordinate system" (OCS). Ideen er at lade eleverne bruge koordinatsystemet som et værktøj til at evaluere deres designs i forhold til nogle prædefinerede mål. Koordinatsystemet visualisere hvordan elevens design performer og dette til at starte en dialog og forstå hvordan designet kan forbedres.

Brugen af koordinatsystemet i en 3D printer i en undervisningen var undersøgt i et felt studie som forgik i en autentisk læringssituation i løbet af en temauge på Sønderbro Skolen. Her havde 36 elever valgt at arbejde med "Teknologi og spiludvikling", i de tre første dage grupper på 12 elever rotere mellem tre forskellige aktiviteter, hvoraf en var 3D printing. Efterfølgende måtte eleverne selv vælge hvilken af de tre aktiviteter de ønskede at tilbringe torsdag og fredag med. Derfor ville der mandag, tirsdag og onsdag være 12 nye elever som skulle introduceres til 3D printing, hvilket blev gjort med et læringsforløb hvor eleverne skulle designe en motorvejsbro. De 12 elever blev delt op i 4 grupper som hver havde deres egen 3D printer, her skulle de samarbejde om at designe og 3D printe en holdbar og billig motorvejsbro. Når den første bro var designet ville eleverne sætte det til at 3D printe og regne ud hvor meget den ville koste at få bygget i stål beton i virkeligheden. Herefter ville eleverne teste broens styrke ved at placere tunge vægt på den indtil den gik i stykker. Den ødelagte bro ville efterfølgende blive placeret på et stort koordinatsystem hvor X-aksen repræsenterer prisen og Y-aksen styrken, på den måde kan eleverne se hvordan deres design lever op til de krav der er sat i opgaven, og diskutere hvad der skal gøres for at forbedre designet og hvordan dette opnås. Herefter re-designer eleverne deres design, hvorefter de undersøger om deres bro har forbedret sig, sådan fortsætter den iterative process indtil undervisningen er slut. Eleverne der valgte at arbejde med 3D print torsdag og fredag måtte selv vælge hvad de ville designe, så længe at de benyttede sig af en iterativ arbejdsmetode og koordinatsystemet til evaluering. I disse dage designede eleverne både der skulle kunne bære en tung last og snurretoppe der skulle kunne snurre længe. I løbet af ugen blev der indsamlet feltnotet samt audio og visual data.

Data fra feltstudiet var analyseret i en video review session, hvor lærerne kommenterede på noget af den indsamlede data. Dette gav en indsigt i deres opfattelse af læringsforløbet samt en forståelse af hvad eleverne fik ud af at arbejde med 3D print i en iterativ process. Yderligere var data analyseret med den fem fasede metode, som også blev brugt i Pilotstudiet, med formål at se om der var tegn på at eleverne lærte 21nde århundredes kompetencer i undervisningsforløbet. Her blev det fundet at undervisningsforløbet understøttede udvikling af Problemløsning og Innovation, Videnskonstruktion, Selvregulering og Kollaboration. Men som det er planlagt nu understøtter det kun i mindre grad de 21nde århundredes kompetancer IT og Læring og Kompetent kommunikation i mindre grad.

Contents

1	Introduction	9
1.1	3D printing in Aalborg	10
2	Participating Schools	12
3	Pilot Study	14
3.1	Methods	14
3.1.1	Data Gathering	15
3.1.2	Data Analysis	18
3.2	Results	22
3.2.1	Observations	22
3.2.2	Interviews	28
3.2.3	Questionnaire	33
3.3	Discussion	36
3.3.1	Methods	36
3.3.2	Results	37
4	Developing Solutions	42
4.1	Generating ideas	42
4.1.1	The Creative Process	44
4.2	The Oresmian coordinate system	46
4.2.1	Literature Perspectivation	47
5	Field Study	49
5.1	Methods	49
5.1.1	The Learning Activity Guide	50
5.1.2	Data Collection	53
5.1.3	Data Analysis	56
5.2	Findings	59
5.2.1	Teachers Review Session	59
5.2.2	21 st Century Skills	62
6	Discussion	73
6.1	Study Design	73
6.1.1	Qualitative Methods	74
6.1.2	21 st Century Skills	75
6.2	Attitudes Towards 3D Printing	76
6.3	The influence of the Design Tool	77
6.4	The Oresmian Coordinate System	80
7	Conclusion	82
8	Perspectivation	84

Bibliography	85
A Article for EDULEARN 2017 Conference	91
B Learning Activity Guides	103
B.1 The Current Version of the Guide	119
C 21st century skills in Denmark	135
D Mammut - Learning Activity Platform	141
E Previous work	152
F Data Tracing Guide	156

Chapter 1

Introduction

Makerspaces, Fablabs, Hackerspaces and the like, are winning impact both as a grassroots movement, but also recently as a part of more formal education [Blikstein, 2013b], [Vossoughi and Bevan, 2014], [Iversen et al., 2015]. The core idea of the maker movement is to provide access to the tools and mindsets of engineers and scientist to a much wider audience, but also to allow for working with these topics in a more exploratory and pupil driven way [Blikstein, 2013b]. As Vossoughi and Bevan [2014] mentions the historical roots of the movement’s pedagogy can be found in the progressive education movement, where playful and inquiry based learning, were promoted by educators such as John Dewey and Maria Montessori. The movement is also highly influenced by the work of Papert [1993] who in term builds on the ideas of Vygotsky according to Blikstein [2013b]. Papert’s constructionism is a theory that states that children learn best when they are engaged in acts of constructing personally meaningful objects [Papert and Harel, 1991]. This is a further development to Vygotsky’s constructivism and adds that the construction of knowledge, that Vygotsky describes, happens best in situations where children use their knowledge to also construct items. Papert believed that the computer was an important tool for creating these personal objects, and the invention of of the LOGO programming language and LEGO mindstorms are examples of his contributions the field [Papert and Harel, 1991]. Mitchel Resnick has developed the programming language Scratch, which is heavily inspired by Papert’s LOGO programming language, but adds multi media features that modern computers are capable of [Resnick and Rosenbaum, 2013].

An important concept in maker education is Tinkering. Martinez and Stager [2013] defines tinkering as an activity incorporating both play and learning, and contrasts it to normal school work where pupils often work towards predefined tasks with a narrow goal. The concept is defined along with making and engineering. Making is here seen simply as a process of creation, where engineering is seen as the process of relating making and tinkering to the more formal

aspects of science [Martinez and Stager, 2013]. Martinez and Stager [2013] describes tinkering as a mindset, and that activities that enable tinkering can provide a more inclusive environment since it can be more easily adapted to individual styles of learning. A similar definition of tinkering is made by Resnick and Rosenbaum [2013], where tinkering is viewed as somewhat opposite to planned work. A tinkering activity might start without a plan, and during idea generation and experiments will be performed and during this process goals might emerge. A tinkering activity may also be initiated with a goal but without a clear idea of how to achieve it [Resnick and Rosenbaum, 2013]. Resnick and Rosenbaum attempts to assess a variety of technologies and explain what makes them "tinkerable", and provide a list of suggestions for enabling a tinkering process.

STEM (Science, Technology, Engineering, and Math) fields has become a focus of many educational institutions, since many industries will depend on a skilled STEM workforce in the future [Martinez and Stager, 2013]. Maker education promises to deliver STEM fields in a meaningful and inclusive way [Blikstein, 2013b]. Another set of skill that the future workforce should master, are defined as 21st century skills. These include, amongst others, critical thinking, problemsolving and collaboration [Greenstein, 2012], and these have been linked to maker education as well [Vossoughi and Bevan, 2014] [Martinez and Stager, 2013] [Smith et al., 2015].

However, certain pitfalls has also been observed when teaching using maker technologies. Blikstein [2013b] describes "the keychain syndrome" which describes the danger of pursuing projects that are too trivial and will offer too high a reward, for little work. Vossoughi and Bevan [2014] also warns that a too narrow focus on STEM fields without a meaningful context, and that a narrow focus on mastering technologies, may also pose a threat to fulfilling the potential of making in education. Kostakis et al. [2014] describes a project in which a group of students are tasked with developing objects for blind individuals to use, providing a meaningful task that can be solved in a variety of different ways.

1.1 3D printing in Aalborg

This study will be based on a project where 3D printers are integrated into schools in Aalborg. The project is a collaboration between the company Create it REAL and the Municipality of Aalborg that began in the fall of 2016. Create it REAL is a research and development company situated in Aalborg, and specialises in control systems for 3D printers, that can increase the speed of 3D printing. A result of their collaboration with the Chinese company Weistek is the 3D printer Weistek Ideawerk Speed [Create it REAL, 2016] which is marketed towards educational use (see figure 1.1). Therefore Create it REAL was interested in testing the 3D printer in a authentic educational setting.

A 3D printer, compared to similar digital fabrication tools such as laser cutters and CNC-mills provides a very versatile tool. One of the limits of 3D printers compared to other digital fabrication tools is the size of the build area, in the case of the Ideawerk Speed it is $15\text{cm} \times 15\text{cm} \times 14\text{cm}$. The advantage of all these technologies, and the factor that separates it from traditional "shop class", and the like, is the apparent professional look of the objects created with these technologies:

"instead of taking home asymmetric and fragile cardboard prototypes, they were building functional 3D objects with a near-professional finish—it wasn't 'school stuff,' it was the 'real thing.'"

[Blikstein, 2013b]

An opportunity to join the project for a small entrance fee was given to six schools. The Municipality would finance the purchase of the 3D printers, and Create it REAL would provide technical support. In turn the schools would have to provide feedback about the technology and the potentials it had for teaching.

This project is an opportunity to investigate how 3D printers are introduced to teachers and how teachers introduce the technology to pupils. In this study we will investigate 3D printers as a means for maker education, and assess the barriers and opportunities the technology currently holds. *The aim of this study is to support teachers in using the 3D printer as a tool for teaching 21st century skills and a tinkering mindset within STEM fields.*

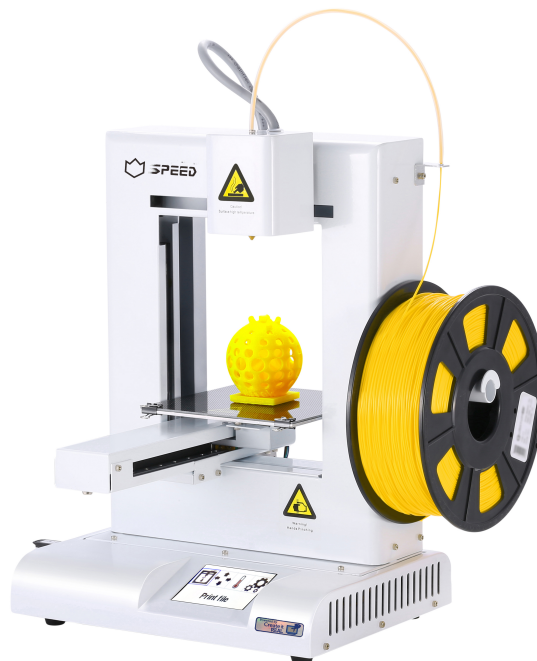

Figure 1.1: The Ideawerk Speed, a 3D printer developed in collaboration between Create it REAL and Weistek

Chapter 2

Participating Schools

The schools were recruited by an employee at the Municipality of Aalborg, who sent an email to all the public schools describing the project, and the requirements for participating in it. Of the schools that were interested (the number of these schools are unfortunately unknown to the researchers) six were elected to be part of the project. Of these six schools only four remained throughout the study due to attrition. The four schools are Hals, Sønderbro, Højvang and Vadum school, which are placed in and around Aalborg (See figure 2.1)

Hals Skole is a rural school east from the City of Aalborg. This school received one 3D printer and the teacher responsible for 3D printing in this school, hereafter referred to as Grace, taught 7th grade (12-13 year olds) Math and History.

Sønderbro skolen is an urban school in the center of Aalborg. This school received one 3D printer and the teacher responsible for 3D printing in this school, hereafter referred to as Bruce. Bruce taught Math but used the 3D printer in an elective class for 7th grade.

Højvangskolen is a suburban school south of Aalborg. This school received two 3D printers. The teacher responsible for 3D printing in this school, hereafter referred to as Harry, taught 6th grade Math and Science. Harry had the primary responsibility for the 3D printing activities, but had help from other teachers he used it in a class where the pupils learned different kinds of crafts.

Vadum Skole is a rural school north west from Aalborg. This school received one 3D printer and the teacher responsible for 3D printing in this school, hereafter referred to as Ash, taught 6th grade Math and Science. None of the schools had a 3D printer before the project, however, several of them had experience with other maker technologies like LEGO mindstorm, Scratch or electronics kits.

Though this project we will collaborate with these four schools, and they will be our source

of data. One of the researchers provided technical support for these schools as part of an internship in Create it REAL (see E). The schools received the 3D printers in September 2016. During the fall of 2016 several meetings were held with the schools and the municipality where the general status of the project was discussed, and experiences were shared. The teachers committed to using the 3D printer in their teaching at least a couple of hours a week. However, the teachers decided for themselves how they would use the printer and planned their own learning activities. The teachers all used Tinkercad¹ as the primary design tool. Tinkercad is a free online CAD tool, where geometric shapes are dragged into a workplane, and manipulated to create an object. The object is exported as an STL file, and hereafter the STL file is loaded into REALvision, which is a slicing software developed by Create it REAL. In this slicing software the STL file is converted to F-code, and the F-code is transferred to a USB key, that is transferred to the 3D printer, and the 3D print can be started.

All the schools also met up once, where all the pupils and the teachers who were part of the project met at one of the schools in a workshop (see E). The whole project culminated in a finale where all pupils and teachers would meet up, and the work that was made by the individual pupils, but also an assignment that done in collaboration between all the schools, were presented.



Figure 2.1: The location of the schools in the project.

¹<https://www.tinkercad.com/>

Chapter 3

Pilot Study

In the initial stage of the study, an exploratory study was carried out to assess how the teachers would introduce the technology into their schools. An exploratory study was chosen since the teachers themselves had the responsibility to include the technology into their classrooms. Therefore, this was an opportunity to observe how this process was undertaken. To make sure that the process could unfold somewhat naturally, we aimed to have very little interference during the process, although the researchers did provide technical support. Since the teachers themselves had the responsibility to find out how to use the technology in their school settings. The focus of the exploratory Pilot Study was to assess whether the teachers achieved learning within STEM fields and 21st century skills and what barriers might exist to hinder this. It is hoped that the knowledge and experience gained from this study, can be used to support other teachers in introducing 3D printers or other maker technologies into their classrooms.

3.1 Methods

Since the 3D printers are placed within schools, it is necessary to go into these settings to gather data by doing field work. Doing field work is often connected with doing qualitative research. Field based data can, among others, come from observations and interviews [Yin, 2015, chap. 5]. All data collected will be qualitative, and therefore a qualitative data analysis is used. We chose to use the [Yin, 2015]’s five phased method, since it is flexible and allows for adjustments which entails that the same method can be used for different types of qualitative data.

3.1.1 Data Gathering

No matter which form of data is gathered there are some practices to consider in order to conduct good field work [Yin, 2015, chap.6]. It is advised to be a good listener and let the participants do the talking and be aware of the subtextual meanings, by reading or listening between lines. At the same time one should be inquisitive and ask additional questions when needed.

Collecting data can take a lot of time, from several days to years in the field. This is not only the researchers time, but also the people participating and helping you with your study. By respecting their time restrictions and preferences it will create a healthy relationship. When conducting field work it is also important to distinguish between firsthand, secondhand and thirdhand evidence. What is heard and seen by the researcher are firsthand evidence. When participants tells the researchers about their experiences the evidence are second-hand. Thirdhand evidence occurs when a participant reports about something some one else have experienced. Even though firsthand evidence might seem like the most reliable it is often not possible to complete a qualitative study based solely on this. When observing, important events might happen somewhere else in the context than where the researcher is present. Therefore, using second and third-hand evidence can be used to cover a fuller range of events, however, having firsthand evidence can be an advantage.

Having data from two or more different sources leading to the same result validity are strengthened, and this is referred to as triangulation. This can be two researchers observing the same event and drawing a conclusion on the background of both observations. [Yin, 2015, chap.6]

Shools	Observations	Interviews	Questionnaires
Hals	17,18,20. Jan 2017	13. Dec 2016	31. Jan 2017
Vadum	8. Nov 2017	17. Feb 2017	31. Jan 2017
Sønderbro	NA	3. Jan 2017	31. Jan 2017
Højvang	NA	16. Feb 2017	31. Jan 2017

Table 3.1: A table showing the instances of data collection. Note that no observational data was collected from Sønderbro or Højvang.

While we want to conduct research and collect data the teachers' schedules and teaching methods should be considered. Therefore, the data collection is done on the teachers terms, by collecting data in situations where they needed technical support and assistance. By doing this we are aligning the teachers' interests with the research. This provided the opportunity to collect data from three sources: 1) Observations, 2) Interviews, 3) Questionnaires. Table 3.1 shows and overview of the data collection.

The observations were made to give the researchers first hand evidence of how the teachers used 3D printers in their learning activities. Since the researchers were not able to observe every class where the teacher used the 3D printer, two collections of secondhand evidence were also made.

It was also chosen to interview the teachers, and asked the pupils to fill out a questionnaire. The group of pupils was somewhat large, and interviewing all of them did not seem feasible within the time constraints, although this did not provide an opportunity to ask further questions. By collecting three kinds of data it becomes possible to triangulate the evidence. Also the data are a representation of the different users' point of view, which gives an understanding of how different users experience the challenges and opportunities (see figure 3.1).

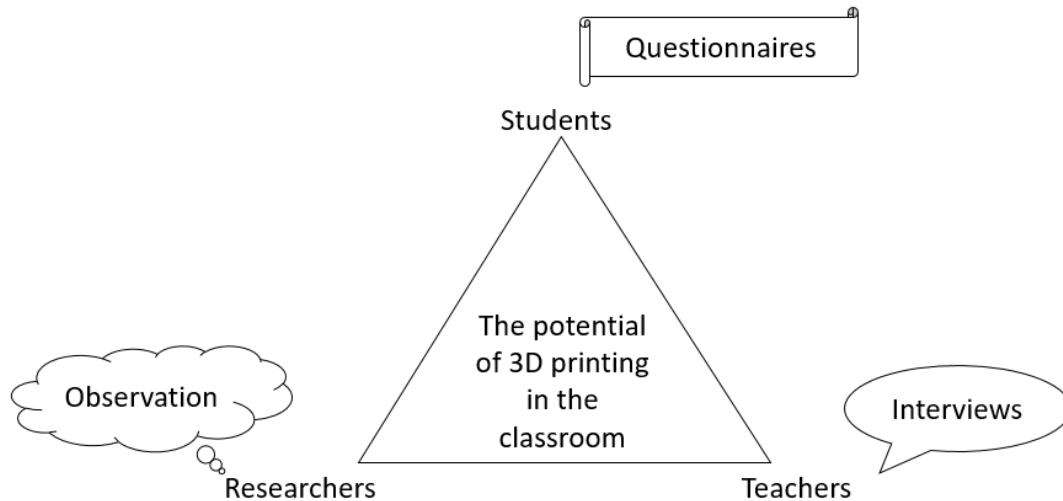

Figure 3.1: A model of the different sources of data used for triangulation

Collecting Interview Data Four interviews with the teachers were conducted to gain knowledge about their experience of using 3D printers during learning activities. A semi-structured interview was used, since it provided the possibility for follow-up questions. The teachers were asked how they had introduced the 3D printer and how they structured the teaching activities around it. There were also some question about what challenges they had faced and overcome and what advise they would give to other teachers in their situations. The interview guide was slightly changed between each interview as interesting topics were brought to attention. This development of the interview guide was a part of previous work, and the guide can be found via Appendix F [Negendahl and Lund, 2016]. Two of the interviews were done in person, while also solving some issues with the 3D printers. The two remaining were conducted using Skype, and audio recordings of all interviews were made. The interviews ranged from between 20 to 45 minutes.

Collecting Observational Data Observational data was obtained through two field studies. One in Vadum and one at Hals, and the data collected was primarily field notes. At Vadum Skole they used the 3D printer as a tool in an elective class named ‘Natural Science’. The observation was during one of the weekly 1,5 hours classes, where the 3D printer was used. Two

girls and eight boys participated in the class, as well as their teacher Ash. The pupils had two tasks, one is very fixed and one more free. The first task was to make a cube with a letter on, also the cube should be able to fit into one of the other group's cubes. In the other task the pupils could design whatever they want, as long as it has a function. If they could not come up with something themselves the teacher brought a back-up task. During the observation we sat in the back of the room and wrote field notes. A quite observational role was adopted, and the class would run its course with little interference from us. This data was also used as part of previous work and was used to determine the focus of this study [Negendahl and Lund, 2016].

At Hals Skole the teachers had decided to host a theme week about 3D printing where 19 pupils from the same 7th grade class participated four girls and 15 boys. In this week the task was to design smart phone covers and other mobile phone accessories. The pupils worked in groups of 2-3 and had to make several versions of their own design. The week would end with a presentation and a promotional video of the products from each team. Our role during this week was less observatory, because many of the pupils needed help when designing their products. The researchers only participated three out of four days, but this were the days where most of the designing and printing found places. Since there were many pupils, and just one teacher we stepped in as action researchers, and supported the pupils in their design process. Therefore, only a few rough notes were taken in the field, afterwards, on the way home, details and more notes were added. Later the field notes were further refined by adding reflections and details. Examples of field notes can be seen in figure 3.2 and all field notes can be found via Appendix F. This is not an unusual way of working with field notes, but of course it is an advantage to create as many field notes while they are as fresh in memory as possible [Yin, 2015, chap. 7].

During the week Create it REAL provided another 3D printer, as the one the school had was not deemed enough to print all the objects that were designed. During the week we would collect observational data, and had had obtained consent forms from parents or guardians from all children which allowed us to obtain audio visual data.

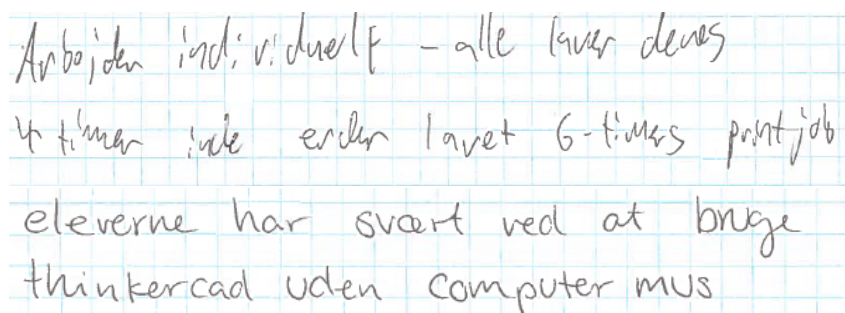

Arbejdet ind: v. duelf - alle laver deres
4 timer i alt er der lavet 6-timers printjob
eleverne har svært ved at bruge
thinkercad uden computer mus

Figure 3.2: Examples of field notes taken from Hals

Collecting Questionnaire Data The questionnaire was given as a part of a workshop day where all the schools were present (see E). During this workshop there were also three other activities regarding 3D printing. 87 pupils were signed up for the workshop, with a show of 66 pupils (35 boys and 29 girls and two who did not specify their gender). The questionnaire did not ask for the pupils' names to promote honesty, and underline that there would be no negative consequences of sharing negative attitudes. However the children were asked demographic questions regarding their age, class, school and gender in order to be able to identify certain patterns belonging to these groups. The main part of the questionnaire consisted of 6 open ended questions. The questions were open ended in order to give the pupils a chance to express themselves more freely. A translated version of the questions is as follows:

- A Has it been fun to 3D print?
- B Which object that you 3D printed do you like the most?
- C What was hard when 3D printing?
- D What was easy?
- E Which things would you wish you knew when you started?
- F Write 3 things that you learned by 3D printing?

3.1.2 Data Analysis

The analysis will consist of three sub-analyses, one made from the data from the Interviews, one from the observational data, and one from the questionnaires. The sub-analyses will be made separately in a way that fits the nature of the data. Hereafter, the results of these conclusions from the sub-analyses are will be discussed, and the overall conclusions from the Pilot Study as a whole will be presented. The three sub-analyses will be conducted using the five phases of Yin's method. These phases are as follows: 1) Compiling database, 2) Disassembling data, 3) Reassembling data, 4) Interpreting, 5) Concluding. [Yin, 2015]

Compiling database The first step is to compile a database, since organized data leads to a stronger analysis. While creating the database the researcher should also get familiar with the data. [Yin, 2015, chap. 8]. During this familiarisation 3 pupils' replies to the questionnaire were discarded, two because the respondents had not 3D printed anything, and one who had only provided brief replies to question A, B and E. Compiling the data bases for the three different sources of data, was done by digitising the data. Furthermore, additional field notes from the observational study, were added retrospectively while compiling the database.

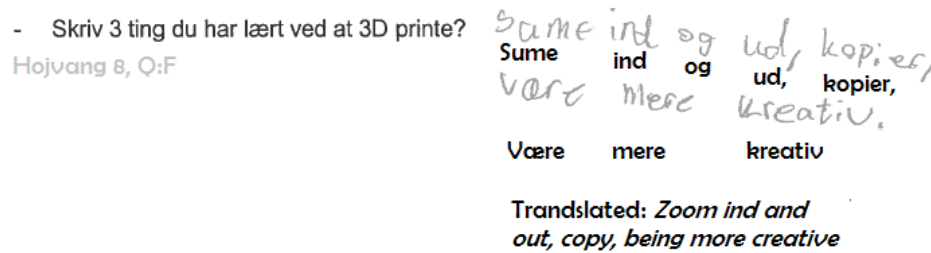

Figure 3.3: An example of a reply to question F in the questionnaire. Transcriptions and translations are added.

The interviews were transcribed, only including relevant parts. For instance the two interviews done in person were carried out during repair of a broken 3D printer, and therefore, some conversation about the repair occurred during the interview, and this was omitted from the transcription. Also mutterings and unfinished sentences were not included, or transcribed into more full sentences. The observations and questionnaires both consisted of hand written accounts, and were scanned in.

During the transcription of the questionnaires a few replies were not transcribed for various reasons. In some cases the handwriting was simply not comprehensible, other times the pupil had simply not replied to certain questions. Other times the handwriting was comprehensible, but the meaning of the reply was not, on figure 3.4, the red text implies that it was hard to interpret the handwriting/spelling. The text was transcribed such that the answers to each separate question was always kept apart. This was done to ensure that patterns could be identified for each question. An example of a reply can be seen in figure 3.3¹. During the transcription some replies were shortened, for instance in reply to the first question some replied: *Yes (it has been fun)*², and this would be transcribed into "fun".

Later, data from all three sources was split into chunks, and added to separate spread sheets, according to the source. All the digitised data was organised in a way that always made it possible to trace the data back to the original source. All data both in its original form, and the compiled data based can be found via Appendix F.

Disassembling data In this phase the data is often coded. This means that a piece of data gets one or more codes describing the content. When doing this it can be an advantage to write memos of the process, as this will help the researcher to remember the progress of the disassembling phases but also prevent making the same mistakes twice. [Yin, 2015, chap. 8]

¹Højvang 8, Q:F

²Sønderbro 1, Q:A

A - Har det været sjovt at 3D printe? *Ja, fordi det er nyt*

D - Hvad har været nemt? *at lave firkanter*

25	vadum	6 Boy	A	Ja fordi det er nyt	New	Fun
26	vadum	6 Boy	B	Marioplante	Model	predefined
27	vadum	6 Boy	C	at lave noget funktionelt	Functional	hard
28	vadum	6 Boy	D	At lave [firkanter]	NA	
29	vadum	6 Boy	E	At finde midten	tinkercad	
30	vadum	6 Boy	F	At lave en kirke	NA	

6	Tinkercad	The participant notes something about tinkercad. This code should always be accompanied by a descriptive code (Ex easy, hard fun)	67
18	New	The participant mentioned that the use of 3D printing was new. Should be accompanied by descriptor (eg-fun, challengin)	6

Figure 3.4: An example of (From top to bottom) Raw data from the questionnaire, the coding of the transcription, and the code description

All the data was in some ways quite traditionally disassembled by writing different emerging codes in a column next to the data chunk, as it was believed that this approach would allow to discuss all the nuances that might exist within these codes. The codes were also given a thorough description, to ensure consistency in the coding. Although, some sources of data was initially coded by one researcher, both researchers would always check all the coded data to ensure consistency. For coded data see Appendix F.

An example of a code from the disassembling of the interview is: *Useful in math* described all the times the teachers talked about how the 3D printer was useful for teaching math. Within this code many different nuances of exactly how the 3D printer was used for math, which disciplines of math it was used to teach, and how efficient it was at teaching these topics.

When disassembling the interview data, 42 unique codes were created, and the 125 data chunks were coded a total of 234 times. The disassembling of the observational data resulted in 17 unique codes, which was coded 155 times over the 83 chunks of data. Finally the disassembling of the questionnaires, resulted in 50 unique codes and the 308 data chunks were coded 593 times. One of the reasons why there are more data chunks in the questionnaires are that the pupils answered the question using few words, where the teachers often spent time explaining their answers.

Reassembling data This phase begins as soon as the researchers starts to note patterns in the coded data. If necessary the Higher levels of codes are made even higher, and themes are developed. This phase does not end before there are a some clear borders of the themes and the analysis are outlined. [Yin, 2015, chap.8]

The reassembling was done by combining codes into higher level codes, which were in turn combined into themes. The reassembling was somewhat different due to the difference in nature between the data from the different sources. The reassembling of the interview data was done by printing out all the different codes that were created from data chunks. These codes were arranged into higher level codes, which were marked by a pink post-it note, and the pink post-its were in turn arranged into broader themes signified by a yellow post-it (see 3.6). The reassembling of the observation and the questionnaire data, was done directly in the spreadsheet.

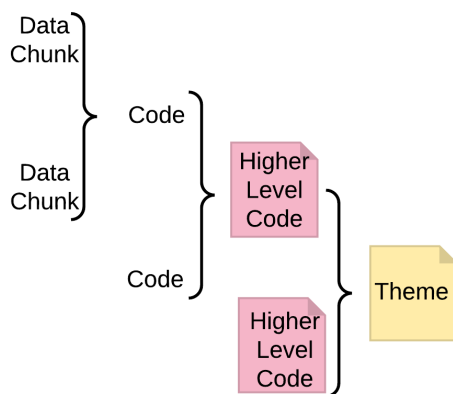

Figure 3.5: Sketch showing how data chunks are gathered in codes. How codes are gathered in higher level codes and how higher level codes are gathered into themes.

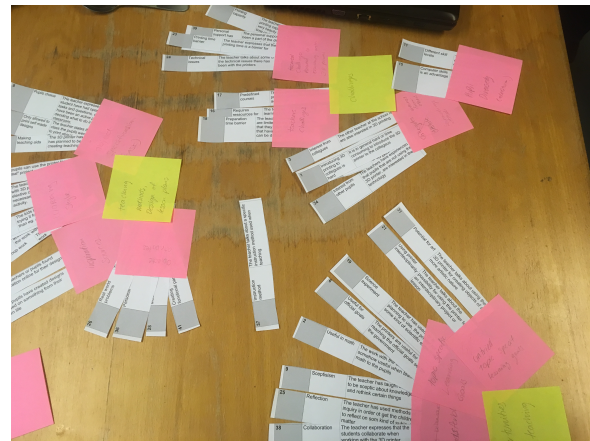

Figure 3.6: A picture taken of the reassembling phase of the interview data

Interpreting In this phase the researchers own interpretations are brought to the reassembled data [Yin, 2015, chap. 9]. In order to create transparency the database is set up so conclusions and interpretations can be traced to the original data it is based on. The information needed to trace a quote from the back are given in a footnote, one example could be this quote from the questionnaire: *You have to use the brain in another way*³, which refers to the reply to question A by the 9th pupil from Hals Skole. Because of the different nature of the databases from the different sources, and explanation on how to trace data can be seen in Appendix F. When quotes are provided they will be translated from Danish.

³Hals 9, Q:A

Concluding The statements that raises the findings into a significance. There are different kinds of conclusions to draw: That more research are needed, to challenge existing knowledge or concluding new concepts and theory. [Yin, 2015, chap. 9]

When analysing with Yin [2015] five phased method it might be necessary to go back an revisit previous phases, maybe the data is not organized enough to make a proper disassembling or the themes are not descriptive enough to start the interpretation. When concluding the Pilot Study, all three sources of data will be compared to find recurring motifs.

3.2 Results

In the following the results from the analysis of three sources of data will be presented separately. The findings of the Pilot Study shows indication of the 3D printer being used as a tool for problem based learning in the STEM field. But teachers with no prior experience have troubles planning this type of learning activities. Furthermore, the schools and teachers are limited in their resources and printer capacity, which can result in de-motivation of the pupils. Thus, funding and time, are elements that must be considered and balanced in order to plan a successful learning activity involving a 3D printer.

3.2.1 Observations

In the reassembling phase five themes emerged: 1) Obstacles, 2) Pupils' behaviour, 3) Object Importance, 4) Learning Goals, 5) Practicalities, and 6) Context. The context theme only includes information about the learning activity and the time, to keep track of the environmental factors. The table 3.2 shows which codes were combined to generate each theme.

Theme	Codes
Pupil Behaviour	Pupils Skills
	Work Ethics
	Working Individually
	Understanding the 3D Printer
Learning goals	Creativity
	Learning by Doing
	Use of Math
Object Importance	Design of Object
	Decoration of Object
	Ownership
	Pride
	Finish Design
Obstacles	Barriers
Practicalities	Design Tool
	Print time x Design time
Context	Time
	Task (Learning Activity)

Table 3.2: Overview of the different themes in the Observation analysis and which Codes were combined.

Obstacles In learning activities including a 3D printer, several technical barriers were observed. Among those are there some direct obstacles which can be avoided if the teacher is aware of them. All these are found when observing at Hals Skole and they will be presented but not elaborated since these are elements that are better avoided. Designing with a touch pad is unnecessarily complicated. Several of the pupils did not bring a computer mouse, this made it hard for them to navigate in the design tool and slowed them down. Some objects were too big to be printed by the printer that was used. At Hals Skole pupils with a Iphone 6/7+ could not fit a cover into the build area.⁴

Pupils' Behaviour This theme consists of codes describing the pupils' attitudes and behaviour. The pupils were, in general, excited about the 3D printing technology and the task they were given. Some pupils were very interested in the printing process itself, and used a substantial amount of time creating time lapses of the printed objects, using their newly created mobile stands (see figure 3.7). Some also showed great interest in learning how the printer functioned, and would volunteer to change the filament whenever that had to be done, and would watch carefully when printer issues were fixed by the researchers⁵.

⁴Obs: 6, 9

⁵Obs: 18, 19, 33, 53

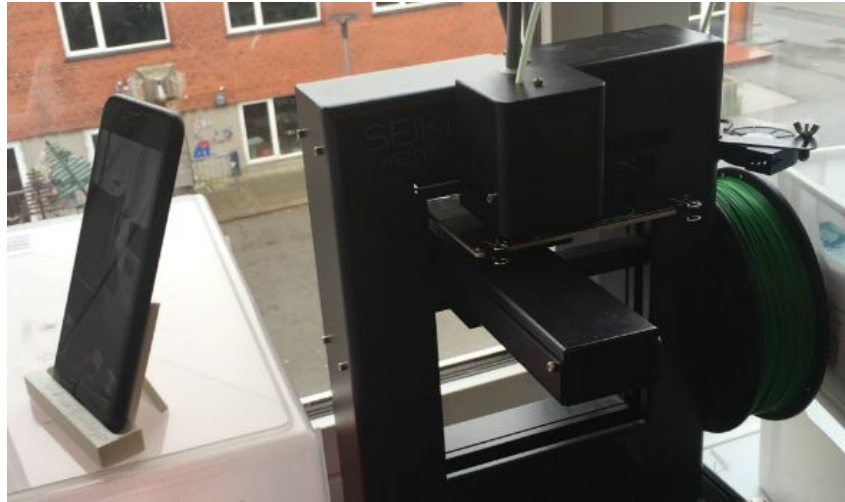

Figure 3.7: Phone recording a object being 3D printed while standing in a 3D printed object.

The pupils enjoyed 3D printing, and put an effort into it and worked hard on their designs, however, this was not the case for all the pupils. The perceived difficulty of the tasks in general varied quite a lot, with some pupils applying math to solve design problems, and others struggling to create basic designs⁶, indicating the possibility for STEM teaching. However, we observed every pupil successfully designed and 3D printed an object. While some pupils managed to create more sophisticated designs than others, all pupils ended up with a unique object which they had designed themselves. On example of the pupil's attitude is described in the following field note:

"The girl group, have not been very interested in the 3D printing technology as the boys, however, their products are as successful as the others"

Obs: 61

This means that involving a 3D printer in a learning activity, provides the opportunity to challenge pupils at various levels. This indicates that a problem based learning approach can be taken when planning a learning activity, and that the problem posed can be solved at different levels. However, the openness of the learning activity in Hals might also have contributed to some pupils not working actively towards the assignment.

Object Importance It was observed during the week that the pupils would work individually, and not in groups even though the teacher had planned that the pupils should work in groups of 2-3. A hypothesis is that the pupils feel a greater personal connection to certain objects, such as the smart phone covers, which makes them want to design their own and makes it hard to work in groups, therefore decreasing the potential for collaboration. This could be objects that the pupils have chance to make personal and have the possibility to own and use⁷. The choice

⁶Obs: 10, 31

⁷Obs: 3, 23

of task and object also have another effect: At Hals school we observed how the different tasks required different use of skills. When designing the phone stand and the earplugs holder the pupils used more math compared to when designing covers. This could be due to the fact that the pupils needed to construct and design the whole object and not just decorate a predefined cover. This does not mean that the pupils did not learn anything from designing and decorating mobile covers. It just means that different objects support different kinds of learning⁸.



Figure 3.8: A blue cover with numbers and a white Phone stander with the logo and name of a E-sport team.

Most of the mobile accessories designed in Hals were decorated in some way. Some of the pupils did make their design themselves and others used an image tool to load a picture into the design tool⁹. This in turn poses the question of what makes a design "personal" to the pupils. Whenever an image tool is used to simply include a logo or brand into the design, the pupils set aside a potentially challenging and creative task of making something aesthetic themselves, in favour of simply using images of their favourite brands. However, the pupils might themselves have a strong relationship to these brands, and in term find the designed object personal. On figure 3.8 two designs can be seen, the first is a blue iPhone cover. This pupil have designed the object by dragging numbers onto the cover and then manipulating their size. This cover is somewhat novel but the numbers have no personal connection to the pupil. The other object on figure 3.8 is a White iPhone stand, decorated with the logo and name of a E-sport team. Still this design is seen as more personal than the cover with the numbers because it has a deeper meaning to

⁸Obs: 7, 13, 30

⁹Obs: 2, 8, 20

the pupil. Before making this observation we were sceptical about letting the pupils use designs found on the internet, because we thought that the pupils would have a low learning outcome from it. However, several of the pupils imported a logo to decorate their designs and that did not necessarily mean that they learned less than the pupils designing and decorating not using existing designs. Of course having the pupils decorate their objects in different ways involves that they use different tools and different skills. But unless there is a specific learning goal the teacher wants to achieve, we do not see a reason to limit the way the pupils personalize their design, since it did not seem to have an effect on the potential for STEM learning, and may add increased motivation for some pupils.

Learning goals Through our observations in Vadum, it was seen that a trial and error approach was generally taken to learning about the technology. Furthermore, Ash had defined a somewhat loose learning goal, that the pupils should design and print a functional object. However, the pupils seemed to have a hard time getting inspiration for this project¹⁰



Figure 3.9: The evolutions of a design. Note that the camera hole is placed on the wrong side on the design closest to the Phone.

During the week in Hals the learning goals were also somewhat unclear. The purpose was that the pupils should create Mobile covers that could be sold, thus teaching innovation and entrepreneurship. However, the pupils ignored this learning goal and simply designed covers and accessories which they would want themselves¹¹. Some of the pupils, however, used skills such as Math and problem solving¹². Other pupils quickly reached a design that they were happy with, and would therefore not push their ideas further. This, combined with the fact that many of the pupils ignored certain aspect of the tasks in order to create personal objects, meant that many pupils did not end up with a design which we as researchers deem innovative¹³. On the other hand several of the pupils did seem to learn something, and these pupils did arrive at their desired designs, by a learning by doing approach (see figure 3.9 and 3.10). This learning by doing approach can also be seen as tinkering, and while we see some indications of pupils tinkering with

¹⁰Obs: 70, 73, 74, 76

¹¹Obs: 15

¹²Obs: 30, 43, 47, 53

¹³Obs: 2, 8, 10, 24

their covers, most examples from this code involves pupils correcting faulty covers. However, it is believed that a learning activity with an innovation focus can be carried out successfully.

In Hals and in Vadum the focus of the learning activity seems to be, to a high degree, to learn how to use Tinkercad. In Hals we had the best chance to observe how the pupils interacted with the design tool. When using Tinkercad the pupils in general had a good understanding of how to drag and drop different types of figures. They also understood how to change the size of a figure and move it around on the work plane. It was harder for the pupils to rotate the figure and moving it up and down in the work plane, also only a few knew how to use the functions which demanded that the pupils interact with the top right menu, where the functions align and grouping can be found. This can be seen in the following field note:

“Several of the pupils need a lot of help to understand the design tool. Most of them can change the size of the figures and drag them into the workplane. Using functions like “group” and “align” is hard for the pupils, and i do not recall having seen any of the pupils using them by them selves. Instead they align by visual evaluation.”

Obs 32

We are aware that the pupils might need to learn how to manage the technology, before they can use it as a tool, to achieve learning goals within STEM. We encourage the teachers to gradually shift their focus and use the 3D printer as a tool, to teach STEM fields and 21st century skills.

Practicalities Another theme that emerged from the data from Hals Skole was the relationship between the printing time and the time it takes for a pupils to design a object. When designing mobile covers all the pupils wanted to have an object printed, on the first four hours at Hals Schools the pupils had designed 6 hours of print jobs. This is of course an issue, and it is believed that it had a demotivating effect on the pupils work. Having more 3D printers would of course solve this problem. However, the teacher actually tried to take this aspect into account, by initiating group work, minimizing the total number of printed objects, which the pupils ignored, in order to make a personal design¹⁴.

¹⁴Obs: 3, 4, 5

Some of the pupils spent a lot of time using the design tool, during this learning activity. The design tool used was Tinkercad running on laptops. Some pupils needed lot of help, both in relation to Tinkercad but also in relation to navigating the computer and using keyboard shortcuts such as copy and paste¹⁵. When in Hals it this field note was written:

*"The pupils need to learn how to use the slicing software and the 3D printer.
The teacher does not have time for both helping the pupils in the design tool,
getting the designs ready to print, and starting the print"*

Obs 37

Quite a lot of the researchers time was spent helping the pupils with the design tool, and Grace would spend a lot of time managing the 3D printing process for the pupils. It is believed that most of the pupils improved their Tinkercad, and computer, skills during the week.



Figure 3.10: Design fails because of support, after this the pupils refrained from using support for future covers.

3.2.2 Interviews

During the data analysis of the four interviews, three overall themes were found: 1) Challenges in 3D printing in education 2) Teaching Methods 3) Learning outcomes. The four teachers will be referred to with their aliases, as described in 2.

¹⁵Obs: 12, 78

Challenges in 3D Printing in Education During the interviews, many different challenges were identified when introducing 3D printing in education (see table 3.3). It was reported that there was a significant difference in skill levels among the pupils, and Ash from Vadum dealt with this fact by giving the more skilled pupils a more difficult version of a task. Harry from Højvang mentions that while some pupils can pick up the necessary skills very quickly, others struggle, and that this emphasises the importance of the teacher having a certain skill level within the topic, and not just presuming that because the pupils are digital natives they can teach themselves how to use the technology¹⁶. He further adds:

"...Some people assume that the pupils are digital natives, and that they can quickly learn everything. But they can't learn everything themselves. They can learn a lot of things, and they learn fast, but often they need guidance to assess what is important, and where they lack understanding..."

Harry Int: 52

Theme	High level code	Code
Challenges in 3D printing in Education	Technical Challenges	Printing Capacity
		Personal support has been appreciated
		Printing time barrier
		Technocal issues
	Teachers Challenges	Predefined courses
		Requires Ressources for teachers to learn
		Preparation time barrier
	Pupil diversety	Different skill level
		Computer skills is an advantage
	Attitudes from the rest of the schools	Interrest from colleagues
		Introducing 3D printing to colleagues is hard
		Interest from other pupils

Table 3.3: A table describing how the themes were created from higher level codes.

From the interviews it became apparent that the teachers have very little time to prepare their lessons and learning activities, which leaves quite little time to get to know new technologies. The prospect of technical issues is also a problem in regards to the preparation time, since fixing these issues will often be done during the preparation time¹⁷. Most of the teachers only have one 3D printer at their disposal, and therefore, technical issues halts the entire learning activity. It is also expressed that a good service agreement would be very important and that the technical support that has been given during this project has been appreciated¹⁸ (see 1.1). Also this indicates the importance of having enough reliable 3D printers.

¹⁶Int: 10 and 50

¹⁷Int: 24 and 66

¹⁸Int: 66, 96, 101 and 123

Predefined courses could have many potential benefits, but mostly it is mentioned that it would save time for teachers who are new to 3D printing¹⁹. It is also mentioned that these predefined lesson plans could make it easier to convince colleagues what 3D printing can be used for specifically within their field as this could otherwise be a challenge²⁰. On the other hand the teachers also reported that there was an interest from their colleagues in 3D printing. Not only teachers of STEM fields were interested in the technology, but teachers of language and arts had also expressed an interest²¹.

Teaching Methods The teachers employed various different approaches in the learning activities with the 3D printers (see Table 3.4). For the sake of both printing capacity, and the possibility of creating more advanced designs many teachers had the children work in groups. However, some teachers have also noticed that group work can also entail that one or more pupils in each group become inactive²². Another approach often taken was teaching 3D printing

Theme	High level code	Code
Teaching Methods	Working Style	Using (3D printers) for project work
		Most suited for elective
		Learning by doing
		Combining with other things
		Group work
	Objects Attributes	Real World Problems
		Personal (objects)
		Model
		Creating Functional Parts
	Sources of inspiration	Inspiration Online
		Inspired by real life
	Task specification	Only allowed to print self-made designs
		Pupil's choice

Table 3.4: A table showing how the theme teaching methods was made from the codes.

as an elective class. Ash seemed quite pleased that he had an elective class in Vadum, since this meant a higher level of motivation and that the pupils had a more similar level of computer proficiency. Bruce had previously had an entire class at once at Søndersbroskolen, but decided to make an elective class instead because he experienced the issues with motivation and computer proficiency that Ash had foreseen. Grace who taught an entire class in Hals, also mentions the fact that a small elective class would be easier to manage because limited printing capabilities, and the lack of patience from her pupils²³.

¹⁹Int: 89, 125 and 20

²⁰Int: 28, 87 and 121

²¹Int: 5, 47 and 97

²²Int: 10, 95 and 99

²³Int: 16, 17, 35, 79, 81, 120 and 123

Ash, Bruce, and Harry all reported that a 3D printer could be used to provide practical examples for topics that are usually quite theoretical in their nature²⁴. In this regard the teachers also used the 3D printer to create models of real world structures such as nuclear power plants and wind mills, but also that the models could help achieve certain curricula goals for exams in both natural sciences and history²⁵. Grace mentioned that it motivated the pupils to create functional objects, such as the mobile phone covers²⁶. Harry mentioned that when the pupils designed something that they knew they could bring back home, they would be extra motivated for creating it. However, he also believed that the learning outcomes of creating objects that placed a higher focus on the design process rather than the end product would entail a higher level of learning, even though the level of motivation was somewhat lower. Ash specified this in the interview:

"My approach to many things is that if the pupils are not motivated, they won't achieve anything. When the learning goal is to teach them something about the technology, they might as well do something they want to do..."

Ash Int: 33

Some teachers have had some restrictions on the tasks that should be done. The most common restriction of the task, was to insist that the pupils only print objects they had designed themselves²⁷. This was believed to make sure that they learned, through the design process. Ash, gave his pupils a high level of choice in what they could create, believing that this would improve their motivation, and that a high level of learning could still ensure through encouragement for reflection²⁸. Harry however, had created some tasks that had a more specific goal and Bruce also started out with some specified tasks in order to teach the pupils the tools²⁹.

Learning Outcomes The teachers described many different learning outcomes from the work with the 3D printers, and also had notions of potential for future learning outcomes (see Table 3.5)

Ash and Harry mentions that it is necessary to go through how to use Tinkercad. It is also mentioned how some few predefined tinkercad tasks could be helpful to ensure that the children can learn it quickly so that the focus can be shifted from learning tinkercad, to learning something relevant to a school topic³⁰.

²⁴Int: 29, 71 and 87

²⁵Int: 7, 42, 88 and 116

²⁶Int: 106 and 110

²⁷Int: 11, 68 and 88

²⁸Int: 10, 32, 33 and 105

²⁹Int: 73, 74, 75 and 77

³⁰Int: 16, 50, 52, 53, 68, 105

Theme	High level code	Code
Learning outcomes	Topic specific learning goals	Science Experiment
		Useful for official (curricula) goals
		Useful in math
	Preliminary Learning goals	Learning Tinkercad
		Learning about the technology itself
	Transferable Skills	Motivation
		Reflection
		Collaboration
		Innovation
		Independence
	Potential within other fields	Potential for art
User 3D printer interdisciplinary		

Table 3.5: A table describing how the learning outcome theme was created.

Grace and Ash mentions some cases in which the 3D printer can be used to teach curricula goals³¹. The work with the 3D printer has mostly been used to teach math topics such as geometry and unit conversion, but also to show that math can be applied in the real world³². Ash had also used the printer to print items that could be used for small science experiments³³. Thus, the 3D printer has been used to teach STEM fields. The teachers also report that the 3D printer can be used as a tool to teach certain skills that are transferable to other situations, once the pupils become proficient with the technology. In this case motivation is viewed as a transferable skill, since it represents the drive and perceived ability to complete a task.

In regards to motivation, or drive, Ash had the notion that it was very important that the pupils had their own say in what they had to create, and that this increased their motivation³⁴. Harry and Grace also supported this idea, and said that creating something personal and meaningful for yourself was a source of motivation and added that even though the motivation could be fading at times, the initial wonder of seeing a new piece of technology actually persisted as the lessons progressed³⁵. In turn Bruce mentioned that his pupils were very motivated by some friendly competition between each other which can also be explained by the fact that the school catered especially to athletic pupils³⁶.

Grace and Ash encouraged reflection amongst the pupils, for instance regarding choice of design task and why certain designs failed to be printed³⁷. Harry and Bruce had both made an effort to make their pupils collaborate, by having one group design an object that should fit together with

³¹Int: 7, 35, 76 and 117

³²Int: 126, 13, 46, 57, 85 and 113

³³Int: 21 and 22

³⁴Int: 33, 37, 38 and 39

³⁵Int: 55, 56, 73, 75, 110 and 118

³⁶Int: 83 and 90

³⁷Int: 10, 15, 26, 32, 33, 34, 102 and 127

another groups' design³⁸. Two of the teachers had used the 3D printers in regards to something called project Edison, in which pupils had to get and test out innovative ideas³⁹. Many of these transferable skills can be seen as 21st century skills.

3.2.3 Questionnaire

Three main themes emerged during the analysis of the data from the questionnaires: 1) Pupils Attitude to 3D printing, 2) Printed Objects, 3) Learning Processes and Outcomes. In general many short replies were given in the questionnaire which means that the interpretation phase was important.

Pupils' Attitudes In general the pupils found 3D printing fun, they found it interesting and enjoyed working on something new and different from their normal school work. They were surprised by the range of possibilities and showed excitement for both the 3D printing process but also for the objects they had printed.

Theme	High level codes	Low level codes
Pupils' attitudes	Reasons for fun	Different Interesting Surprised by range of possibilities New
	Negative attitude	Boring Desire to print more
	Difficulty	Hard Easy Challenging
	Aspects of fun	Surprised by range of possibilities Excited for the process Excited by the end product Printing process is fun
	Desire to know	Desire to modify Desire to learn more

Table 3.6: A table showing how the Pupil's attitude theme was created

³⁸Int: 7 and 74

³⁹Int: 46 and 63

Even though the pupils found 3D printing fun, they did not always find it easy. The responses implies that the most had to learn how to use the design tool and how 3D print. One pupil writes:

"In the beginning it was hard, but now I think it has become okay easy"

Pupil from Vadum: 3, Q:C

This is just one of many examples that describes how learning to 3D print have been an challenging experience. When asking the pupils what they wish they had known earlier they expressed that they would have liked to know more about the different features in their design tool Thinkercad. This implies that learning to use the design tool was not easy, but possible and that most of the pupils would benefit form spending time getting familiar with the design tool. Still some of the pupils did find 3D printing difficult, and others responds that everything was easy. This implies that the pupils were and still have different skill levels.

When the pupils expressed negative attitude about 3D printing it was often caused by the waiting time. The pupils found it hard and boring to wait until it was their turn to get a design 3D printed. In addition there is a group of pupils that found 3D printing in general boring and expressed that it is not one of their interests. Still having to wait is one of the clear down sides of 3D printing from the pupil's point of view.

Learning processes and outcomes Through the questionnaire it is seen that the pupils believe they have learned something (see Table 3.7). A code dubbed "hard first, then easy" was used when the pupils expressed how some things were hard at first, and then became easy: An indicator of having learned something. This was coded for nine times see Appendix F. Some of them also note that they have learned 3D printing by doing it. In general the pupils had some difficulties describing what they had learned.

So the pupils have learned something, but what? When asking the pupils what they have learned, they most often answered that they learned to use the design tool, Thinkercad, or some specific functions inside Thinkercad such as aligning objects or camera control. The code Thinkercad was the most frequently used when coding the data. The pupils have also got an understanding of what the 3D printer can and cannot print. Another thing the pupils are aware of is that 3D printing often demands precision and a lot them found it challenging to make pieces fit together and measure things and some also mentioned learning this and it is also an important part in many STEM deciplins. An example of this is a boy replying that the three things he learned by 3D printing was:

"To measure it, to look at it before you print it, and using my head"

Pupil from Hals: 2, Q:F

This pupil also learned that critical thinking and concentration are skills that are useful when 3D printing, other skills found in the data was: Creativity, thoroughness, collaboration and reflection. These skills are not very well represented in the data set. Still it is interesting that the pupils recognize that 3D printing involve and train general skills that are also useful in other situations.

Theme	High Level Codes	Low Level Codes
Learning processes and outcomes	Measuring techniques	Measuring techniques Tolerances Precision Scale
	General skills	Concentration Thoroughness Scepticism Collaboration Reflection
	Learning processes	Hard first then easy Learning by doing
	Design tool	Tinkercad Camera Controls Learned tech specific task Support Understanding 3D
	Creativity	Getting ideas Converting ideas to reality Total

Table 3.7: A table describing how the Learning processes and outcomes theme was created

Printed Objects When describing the favourite object that the pupils have printed the main two attributes described were something personal and something functional (see Table 3.8). Often the object was both, like a mobile cover which was something the pupils from Hals Skole had printed or a key chain that most the pupils from Højvang Skole had printed. These objects were deemed both functional and personal since they served a function in the real world, requiring some skills, but they were also quite personal because the pupils would modify them to include their names, the logos of their favourite football teams or other brands, etc.

The have experienced different kinds of barriers when printing an object. First of all there are a technical one, the print can fail due to some problems with the printer or the design. Another barrier is that some of the pupils did not print a lot of different objects, and therefore, their favourite object was the only one they got to print. The waiting time can also be seen as a barrier to get things printed, and thereby also to achieve the full learning potential.

Theme	High level codes	Low level codes
Printed Objects	Predefined brands	Predefined Brand Logo
	Barriers for printing	Did not print much Waiting time Failed print
	Personalization	
	Model	
	Functional	

Table 3.8: A table describing how the printed objects theme was created.

3.3 Discussion

In this section our choice of methods and the results of the analysis will be discussed. The discussion focus on the most interesting or important aspects of the use of findings and how they relate to other theory. However, fist the choice of methods of data collecting, and how these can have affected the analysis will be discussed.

3.3.1 Methods

In the Pilot Study data was gathered from three sources. One of these was an open ended questionnaire, that 68 the pupils who participated in the project replied to. This in general, provided a good overview of the overall experience of the pupils participating, and showed that not all pupils found the learning activities with the 3D printers interesting. However, there are some problems with the validity of the questionnaire that was used. The questions were generally framed poorly, and resulted in a somewhat limited depth of the replies. One example is the last question, F, where the pupils were asked to name three things they had learned by 3D printing. On average each pupil wrote two things they had learned, not three. This indicated that it might be difficult for the pupils to answer this type of question with a sufficient level of introspection. For instance, even though Tinkercad is a frequently coded learning outcome, it might not be representative of the actual learning outcome. Also question A asked the pupils whether it was fun to 3D print, but a better phrasing might have been "which aspects of 3D printing has been fun?".

Pilot testing the questionnaire could have improved the results, and in general a further development of a questionnaire is needed in order for it to become a better tool of investigation. The questionnaire was successful in providing a large amount of data within the time frame, and did

provide an overview of the pupils' assessment of working with the 3D printers.

In general, we argue that the interview and the field observations were the more fruitful sources of data. Here we got a nuanced view of the barriers and opportunities, which occur when the teachers planned and hosted learning activities with a 3D printer. When we wanted to be observers at Hals we did in fact become supporting teachers, still it gave us a good indication of the challenges teachers face, not only when using a 3D printer. However, this did mostly provide us with chunks of reflective data, where several observations were gathered in on data chunk, meaning that the analysis was not based on detailed accounts of instances. Hosting the interview, would have been preferable to do in person all four times. However, when starting to disassemble the data from the interview it was found that even though only four teachers were interviewed the content of the data are still quite rich. The teachers had some quite interesting and well thought out ideas about what had happened but also thoughts about future prospects. Furthermore, the teachers all had a different approach to teaching with the 3D printers, and it was very important that the analysis would not blur these important distinctions between the schools. Throughout, the analysis, it was important to consider the richness and overall quality of the interview data, while at the same time allowing to generate general conclusions from the data. However, the interviews, but especially the field observations, can also be prone to certain biases. Sometimes, it can be tempting as a researcher to focus mostly on the successful instances that occurred during the learning activity. This is why the validity is strengthened by triangulating the data with both firsthand, secondhand and thirdhand evidence, where some will represent the pupils attitudes in a more fair way, and others will produce deep and rich data.

3.3.2 Results

Throughout some findings occur repeatedly through the analysis regardless of the data source. These are: 1) Printing Capacity, 2) Importance of Design Task, 3) Learning Potential. Furthermore it will be discussed how our findings are related to theory.

Printing Capacity The schools in this study had either one or two 3D printers at their disposal, and in all three sources of data, it was seen that this was problematic. This was an issue for the teachers, since they could not always find the time to print whatever designs were made during the class and they had to spend their preparations time printing the remaining. Because of this, Ash, Harry, and Bruce chose to use the 3D printer for elective classes, to have less pupils in the class. In the questionnaire the pupils also mentioned the printing time frequently and they found it hard to be patient, and wait for the design. Furthermore, indications of this was also found during the observations.

Since this issue is present within all three sources of data, it can be seen as a quite solid finding in this study. It is highly problematic, as it is seen that it entails a lower level of motivation and concentration. When pupils realise that their print might not be done within the next three or four hours, they naturally lose interest. When applying the theory of flow state to this aspect of 3D printing, what is happening is that the long waiting time means that the pupils become bored quickly, and thus suffers the negative consequences of this [Barret, 2010]. If the waiting time becomes so long that the pupils actually believe that it will result in them not being able to finish a task, this can also be seen as a threat to self efficacy [Bandura, 1993].

Also some teachers would not let the pupils themselves control the printing process. This entailed that the pupils lost control over the process itself. This meant that pupils could have a hard time understanding what would cause a long printing time. When we observed in Hals, the teacher would take the STL file whenever a pupil was done designing it, and then go through all the necessary steps to get the print job done. Ryan and Deci [2000] regards control of a learning process as a key factor in ensuring motivation. Therefore, we argue that giving the pupils the responsibility of controlling the entire printing process could result in a high level of motivation, and would also allow the teacher to spend more time supporting the pupils in other ways.

Throughout the study certain solutions to the problems with printing capabilities were found. One of the most obvious solutions is to buy more 3D printers, however, other solutions was also found in the data. Another was to let the pupils work in groups where they were to work together on a single design which reduced the amount of printed objects significantly. However, some teachers mentioned that when doing group work, there always seemed to be a few individuals in each group who would not work fully focussed. Therefore, we suggest another strategy, making sure that there are other aspects to a task than 3D printing and designing. We argue that if the task that is assigned to the pupils also entails, for instance, math calculations or other STEM activities, it can be easier to ensure that everyone in a group has work to do, but can also make it easier to handle waiting time.

Importance of Design Task The teachers in this study were all new to using 3D printing technology as a part of their learning activities. They had the responsibility to plan these learning activities themselves, and also to define the learning goals. The design task was seen to have an influence on, the way the pupils worked and the learning outcomes. Most of the teachers seemed to have vaguely defined learning goals, which meant that pupils had freedom to decide how their design should be.

An aspect of the design task that seems significant is whether the designed object has a personal meaning to the pupils, or if they have feelings of ownership towards it. It is seen in the questionnaire that pupils enjoyed these types of objects (see figure 3.11⁴⁰).

Hvilken ting, som du har 3D printet, var du mest glad for? Justin bieber nøglering

Figure 3.11: Pupil expressing that her favorite object was a Justin Bieber key chain

When we were observing in Hals school, the teacher had planned for the pupils to work in teams, in order to reduce the total amount of printed objects. However, as soon as the design process was started, all groups were abandoned, and the pupils created mobile phone covers for their own phones. Because the object had a very personal meaning for the pupils everyone wanted to create their very own personal design, without compromising with their team mates.

In the data collected from the interviews, the teachers confirms the effect of personal items and that it has both its benefits and pitfalls. One of these benefits, is that creating these types of objects will increase the motivation towards the learning activity. According to Ryan and Deci [2000], Bandura [1993] and Barret [2010] increased motivation, provides a higher learning outcome. One of the pitfalls of such objects is that it can bring too much attention towards the end product, instead of the process of designing, as stated by Resnick and Rosenbaum [2013].

”Too much emphasis on the final product can undermine the experimentation that is in the heart of tinkering.”

Resnick and Rosenbaum [2013]

The teachers do seem to see the potential for rich learning, but they seem to have a hard time moving away from simple pleasing designs. This could be an example of the keychain syndrome [Blikstein, 2013b]. This in turn might be why we see that teachers report that personal objects might not produce as high a learning outcome. Thus, we argue that several of the learning activities in this study fall victim to the keychain syndrome. During the workshop in Hals some pupils simply found a predefined model of a mobile cover and wrote their name on it. These pupils produced something that was very satisfying, but required very minimal effort to design. Therefore, to achieve higher levels of learning within the STEM fields the design task should be planned to avoid key chain syndrome. This could be done by introducing more specific requirements of the task or framing the learning activity differently, since some pupils did use STEM competences when designing mobile covers.

According to constrictionist theory, it should, however, be possible to create learning activities that stresses both personalisation, and enhanced learning capabilities [Papert and Harel,

⁴⁰Højvang: 6, Q:B

1991] [Papert, 1993]. Another source of motivation in design tasks, seemed to be tasks that were related to real life problems. This was an approach emphasized by Ash, but was also seen with the mobile phone covers created in Hals. This is also an approach described within constructionism [Papert and Harel, 1991], which has also been used along with digital fabrication [Smith et al., 2015] [Blikstein, 2013b] [Kostakis et al., 2014].

Teachers should be very aware of influence of the design task, since it greatly affects the level of motivation and the potential learning outcomes.

Learning Potential It was found throughout all sources of data that there was learning potential within STEM fields, for instance, when the pupils design objects for 3D printing they will use a certain level of math in dealing with units and geometry. The teachers also mention the possibility for using the 3D printer for interdisciplinary learning activities, and that group work was often encouraged. Furthermore the pupils were also motivated by working on project projects that they had a personal interest in. These are all important aspect of Problem Based Learning (PBL), as described by Allen et al. [2011]. Furthermore, these competencies are also aspects of 21st century skills such as collaboration and real world problem solving [Microsoft, 2012]. Therefore, it is argued that the aspects of PBL can also be described through 21st century skills.

The theme week in Hals was planned to incorporate many of the aspects of PBL as pupils of various skills levels were to participate in the same activity. The teachers also had various ideas for how to further teach these topics in future learning activities. However, it can be questioned how much the values of PBL was expressed in this learning activity, since, very few pupils created the mobile cover with any kind of market perspective, and instead made objects they would want themselves. Maybe due to the low printing capacity, and, since there was no clearly defined formulation of a problem where the solution could be tested, the pupils became victims of the key chain syndrome [Blikstein, 2013b].

The reason why we do not see PBL as more widespread in the use of the 3D printer might stem from the fact that the teacher often believed that the pupils had to learn certain technology specific skills before they could harness the true learning potential of 3D printing, and that they found that these technology specific skills were more easily taught through traditional lectures, and work with certain tasks. This use of hybrid pedagogies is often used in similar contexts [Vossoughi and Bevan, 2014]. On the other hand, Martinez and Stager [2013] emphasizes the importance of getting the pupils to explore quite early in the learning activity.

Throughout the three sources of data it is seen that the pupils had varying levels of motivation. In regards to motivation, Ryan and Deci [2000] mentions that motivation is best regarded in terms of a spectrum that runs from complete lack of motivation to intrinsic motivation, with different types of extrinsic motivation between these. Some pupils showed signs of being intrinsically motivated, as they showed great interest in the learning activity and printing processes. We argue that understanding and being able to control the printing process, will increase motivation, since, it provides the possibility for the pupils to attain more control over their own learning [Ryan and Deci, 2000].

As observed in Hals the pupils can learn to manage all aspects of the 3D printing process. Therefore we argue that by increasing the printing capacity, and teaching the entire 3D printing process to the pupils, they can become in control of their own learning processes. Furthermore, we argue, based on questionnaires and the observations, that a learning by doing approach can be used by the pupils, to get acquainted with the technology and the design tool.

Chapter 4

Developing Solutions

In the Pilot Study some of the challenges and opportunities that teachers and pupils are facing in the initial period of using a 3D printer. In this chapter this knowledge will be used to develop a solution which can make it easier for teachers in the future to introduce 3D printing to their pupils. By using principles from the method "The Creative Platform", a creative process was planned where we can use our knowledge freely to create new and innovative solutions to reach that goal [Hansen and Byrge, 2013, chap. 7].

4.1 Generating ideas

Creativity can be a controversial topic, and researchers have not reached a clear consensus on its definition. For the purpose of this study we use the term creativity in the same way as Hansen and Byrge [2013] who define it as: *unlimited use of knowledge*. This involves seeing patterns across contexts and being open to try out new solutions. This means that one should be able to use knowledge from one field to solve a problem in another, and this is called "horizontal thinking". This is something everyone has the potential to do, but can and should be trained, however, for some people it can be close to impossible, because one has to break out of normal thinking patterns. There are different ways to help people be creative and use horizontal thinking. Knowledge which has been used recently is the easiest to apply, therefore, stimuli can be used to unlock older knowledge. Besides helping the participants use their horizontal knowledge a creative process should also: 1) help the participants to only focus on the task 2) make sure all participants have the same focus at the same time 3) and avoid the feeling of judgement. [Hansen and Byrge, 2013].

In the following it will be described how the creative process was planned and executed, and how it relates to the method developed by Hansen and Byrge [2013].

Focus of the Creative Process In the creative process the participants should come up with as many solutions as possible. People are very easily influenced by stimuli, which can be helpful to get them out of their normal thinking patterns. However, stimuli can also present certain thinking patterns which people are likely to use. The "problem statement" should be formulated as open as possible in order to allow the participants to use horizontal thinking. The purpose of this creative process is to: *Develop a support tool to use 3D printers in education.* This provides an open problem statement, but encourages the participants to develop ideas for different users in different contexts. [Hansen and Byrge, 2013, chap. 1 and 2]

Participants When generating ideas in groups there is more knowledge available, which can lead more exciting ideas than the ideas a person could develop alone. The group will affect each other which will help them break free from limiting their thinking patterns. [Hansen and Byrge, 2013, chap. 1]. The creative process was only performed by the researchers themselves, and no external experts were included in the process. This was due to the fact that the process was planned to take about six hours, and therefore it was not feasible to have other participants taking that much time out of their schedules. The researchers through their work in the Pilot Study, also gathered knowledge, which can be used in the generation of ideas.

Planning This creative process is planned by one of the researchers and facilitated by a slide show, meaning that the two researchers participated by following 3D activity displayed on a computer screen (see Figure 4.1). This approach was chosen to increase task focus and parallel thinking. First of all as few as possible should know about the process which was why only one of the researcher planned the process. Furthermore, by having a computer support the activity, the researcher who planed the process had a better chance to participate, since her focus could be on generating ideas instead of facilitating the process [Hansen and Byrge, 2013, chap. 4]. Also the task would always be visible as a stimuli [Hansen and Byrge, 2013, chap. 2]. In addition to keep parallel thinking the process follows the principle of "one task one deadline" and only one task is displayed at a time [Hansen and Byrge, 2013, chap. 4].

Before the creative process started the surroundings was cleaned up and phones was put away, to make it easier to avoid distractions and maintain a strong task focus [Hansen and Byrge, 2013, chap. 3]. To avoid time pressure a whole day was used to run the creative process which started 8:30 in the morning [Hansen and Byrge, 2013, chap. 4]. The process as described by [Hansen and Byrge, 2013, chap.4] will normally start with an introduction to the problem at

hand, and what the problem statement is. However, since the only participants are the researchers, this was not deemed necessary.

4.1.1 The Creative Process

The Creative Platform as a method is typically build up with two types of blocks "3D cases" and "3D activities"¹ which will be used in turn. 3D cases are small exercises which will create flow, task focus and train the participants' competences in creative behaviour. Afterwards, the participants will use these competences to solve the task they have been given in a 3D activity. [Hansen and Byrge, 2013, chap. 6].

However, in this creative process there will only be 3D activities, and the 3D cases will be omitted from this process, since they are not suitable for only two participants. It is possible to have process without 3D cases, but it can be harder for the participants to say "yes" to each others ideas and for them to use their horizontal knowledge. Therefore the process should try to make up for that. [Hansen and Byrge, 2013, chap. 6]

When generating ideas the ideas should come on que, and there are three elements in "idea skill": spontaneity, flexibility and originality. Spontaneity, refers to the fact that the ideas should come naturally and fast to the participants, and that there should, to begin with, not be any reflections or judgements holding the generation of ideas back. Flexibility refers to having solutions withing different categories. Finally originality refers to the fact that the ideas should come from escaping the ordinary thinking patterns, and producing original ideas as a result. [Hansen and Byrge, 2013]

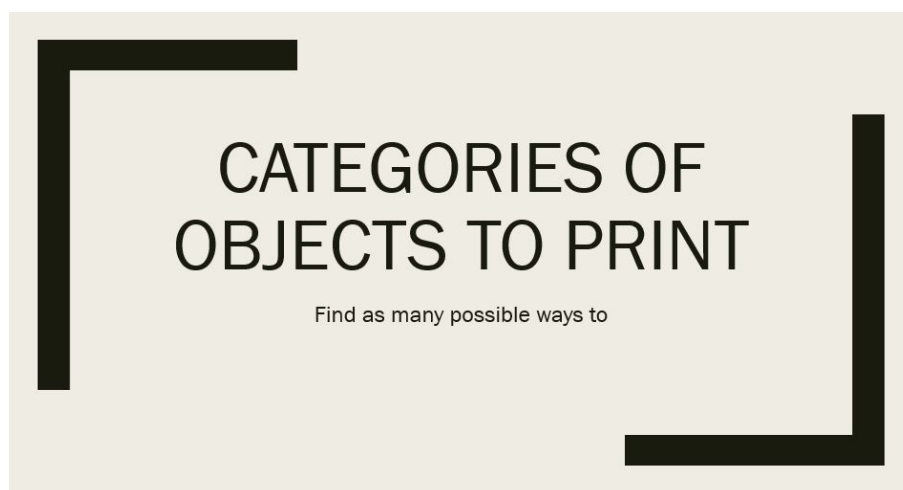

Figure 4.1: The idea generation was facilitated by a slide show, this is one of the tasks the participants was asked to do.

¹the "3D" component of 3D cases having nothing to do with 3D printing or 3D geometry

In the first part of the idea generation the facilitator provided tasks to open up for horizontal thinking. The 3D activity would be presented with a slide show, giving the participants a stimuli to idea generate over. The participants were not limited to write things related to 3D printing down, and the further away they came from 3D printing the more the horizontal knowledge they could use. Each idea would be written on a yellow or pink post-it in order to keep track of the ideas and process. After each 3D activity the post-its were presented one by one in turns and if a new idea emerged, it was added on a new post-it. The participants would use the following 3D activities to generate ideas: 1) Different ways to give information to others, 2) which skills the pupils could learn, 3) which information the teachers needed, 4) categories of objects to print. The first 3D activity was made to generate new ideas of how to communicate with the teachers or the pupils. The last three 3D activities was to remind the researcher of their knowledge regarding 3D printers in education, when looking at all the post-its this was found that:

- **Different ways to give information to others:** 29 unique post-its was made during this 3D activity, meaning that not two was exactly the same. The ideas can also be placed inside different categories like: verbal, digital, written, math, and body language. Ideas like *in secret codes*, *whispering* and *Braille* are some of those which are the most original and far away from 3D printing.
- **Skills the pupils could learn:** This 3D activity generated 42 post-its with several that where not unique. Also most of the post-its contained skills which are presumably possible to be taught involving a 3D printer. However, there are a some diversity in the topics and there are several different categories: Crafts of tools or jewels, to understand experiments, to understand mechanical engineering, or learn about design processes.
- **Which information the teachers need:** This 3D activity produced 21 post-its which are also very closely related to 3D printing. The post-its are regarding all parts of the 3D printing process but besides that there is not much variety.
- **Objects to print:** This 3D activity only generated 13 post-its, however they were different and in different categories like: functional, personal expression and models.

Hereafter, all the post-its were spread across the table for the next part of the idea generation where they would be used as stimuli (see figure 4.2). In the next 3D activity the participants were asked to match the post-its into a solution, or use them as inspiration for a new idea, here the participants could freely come up with any solution. The next 10 slides were 3D activities that should to challenge the participants into making innovative solutions, by adding constrains so that the idea had to fulfil a specific purpose. This could be solutions supporting different phases in the 3D printing process, or solutions influenced by resources. This meant that the participants needed to come up with different kinds of solutions to overcome the different challenges, which leads to an flexible idea generation. This resulted in several blue post-its filled with ideas. The

ideas were again presented in turns one by one, where new ideas was added if they came up. In the end there was 49 blue ideas post its.



Figure 4.2: How all the idea post-its was put on the table to help the participants generate ideas.

The last 3D activity was to choose an idea to further develop, first the idea were sorted. The ideas were divided in "obvious ideas" and "ideas with potential". The obvious ideas are not necessarily bad, and most of them would be useful for teachers or pupils, but they did not inspire us and were therefore chosen not to work with further. Afterwards we choose one of the remaining ideas in which we saw potential and wanted to refine. The ideas we chose to refine was to let the pupils use a coordinate system to evaluate their designs and reflect upon their process.

4.2 The Oresmian coordinate system

Prior to this study we have experience with a learning activity where pupils designed and 3D printed highway bridges in an iterative process (see E). In this approach to teaching with a 3D printer, the pupils tested the strength of their design and then re-designed it in an iterative process to learn form their mistakes and develop their design. The idea is to introducing a coordinate system into a similar learning activity. The coordinate system will be called the Oresmain coordinate system (OCS), and it's purpose is to help the pupils to talk about and evaluate their design. The approach is named after the French natural philosopher Nicole Oresme, and makes use of a large coordinate system. The axes of the coordinate system are by default unlabelled, but can be filled out with units and numbers which fits the designed object. The evaluation system, as envisioned now, requires that the design task can be evaluated on at least two numerical parameters. In the highway bridge learning activity one axis could be strength and the other could be price, since the task was to make a strong yet cheap design. After having made the axes

the pupils can reflect upon where a good design would be placed in the coordinate system, and thus attribute the goal of the class (e.g. creating a light and strong design) with the abstract concept of the coordinate system. When finished with one or more designs they can place them inside the coordinate system to show how their design have developed. Hopefully this will help the pupils reflect and evaluate their designs, and make it easier to improve them. Also we hope that the coordinate system will support collaboration in groups, since it shows how a design is performing, and give the pupils a chance to discuss how to improve it. Depending on how the parameters of the coordinate system is obtained, the approach can support learning within various STEM fields.

4.2.1 Literature Perspectivation

The OCS is an approach to structure a learning activity. In the findings of the Pilot Study it was apparent that the teachers, who were new to the 3D printing technology, needed methods of structuring their learning activities, in order to achieve a tinkering mindset, develop 21st century skills, when teaching STEM field 3.2

A survey of literature provides further evidence that the barriers found in the Pilot Study are also present in other situations. In the Pilot Study it was found hard for the teachers to engage the pupils in reflection and in evaluation of their designs. This barrier has also been described as:

”These challenges include teachers’ ability to support such complex activities and processes, the need for reframing technologies as flexible materials for design, and the design of systems and tools for assessing reflective and design based competences that are relatively new to schools”

Iversen et al. [2015]

It is also described how school settings can be very different from after school activities, especially in terms of motivation [Iversen et al., 2015] [Smith et al., 2015] [Bekker et al., 2015]. They argue that the otherwise free and playful activities that are encouraged in making and tinkering communities might not thrive that well in the current frame of schools. It is argued that a slightly more structured approach might be necessary at the moment and that:

”The idea of these labs as spaces for ”unattended” discovery and exploration ends up increasing the disparity between novice and expert”

Iversen et al. [2015]

This tendency is also seen in the interviews with the teachers, who believes that an elective class would be well suited because of these differences. Through their interviews with stakeholders

within education Bekker et al. [2015] also arrived at the conclusion that more structure was needed, especially to push the pupils to go beyond the initial product, and reflect over the process. In the article the Reflective Design-Based Learning framework is presented [Bekker et al., 2015]. This framework is derived from similar frame works for university students, and adapts these ideas for a younger audience. During the article the researchers investigate different electronic toolkits using the framework to assess them, and conclude that:

“. good support needs to be provided about how to plan, manage, and assess the progress in design-based learning processes for teachers”

Bekker et al. [2015]

Smith et al. [2015] implements an approach for design thinking in maker education, after an exploratory study where different challenges were found. These challenges also included a lack of structure, and a lack of tools for the pupils to examine, navigate, assess their design in a more broad and reflective sense. Because of these findings a framework for design thinking was implemented with positive results, and this method seemed to increase the richness of the learning situation [Smith et al., 2015]. However, this approach to teaching was developed mostly in regards to electronic tool kits, and therefore it was decided to conduct a field study to test the OCS in an authentic situation, with 3D printers².

²Another idea dubbed Mammut was also chosen, and this two idea was developed through workshops with stakeholders. However the focus in these workshops were on MAMMUT, and the workshops only had a limited success. Therefore the focus for the research shifted towards testing how pupils can evaluate their designs using OCS. This work was left in a somewhat early stage of development, but can be seen in Appendix D.

Chapter 5

Field Study

In this chapter it will be investigated how the Oresmian Coordinate System (OCS) can contribute to a learning activity involving a 3D printer. At Sønderbro Skolen, in which Bruce works (see 2), a theme week was planned in April 2017. One of topics of the week was "Technology and Gaming Development" which around 36 pupils had chosen to work on. These pupils are split into three groups, and in the first three days they would rotate between three different workshops, where one would be about 3D printing. In the last two days of the week the pupils would choose which workshop they would like to attend. The theme week would be the first time the involved teacher, hereafter referred to as Rachel, would use a 3D printer in her teaching and also the first time most of the pupils would use the technology, which provides the opportunity to investigate how the OCS can be used in a authentic teaching situation and what learning it can support.

5.1 Methods

In order to investigate how the OCS can contribute to pupils learning STEM and develop a tinkering mindset, the learning activity has to be planned. With knowledge from the exploratory study (see 3), we wanted to help Rachel to make a good learning activity, however, we wanted her to plan and carry out the activity herself. Therefore Rachel will receive a "learning activity guide" and an increased printer capacity. Because the school are a part of the project between Create it REAL and the Municipality of Aalborg they have one 3D printer (see 1.1), however, it was found in the Pilot Study (see 3.2), that having one 3D printer in a learning activity for 12 pupils are not considered enough. Therefore Create it REAL supplied 3 extra 3D printers to use during the theme week, meaning that four printers were available in total.

The contents of the learning activity guide, and therefore, also the learning activity itself was planned in collaboration with Rachel in the course of two meetings. At the first meeting we presented the OCS and discussed what the pupils should design and which knowledge Rachel need in order to plan the learning activity and guide them throughout the days. Because the pupils are rotating the first three days, different groups of pupils have the same learning activity on Monday, Tuesday and Wednesday. The learning activity for the first three days need to take into account that some of the pupils have never tried 3D printing before. It was chosen to introduce the pupils to 3D printing by having them designing models of highway bridges, since this is a learning activity we, as researchers, are familiar with and which in fact inspired the idea of the OCS (see E and 4.2). Therefore, it was known that this learning activity can involve an iterative process which could be supported by the OCS. Thursday and Friday there needed to be a new learning activity for the pupils who chose to continue to work with 3D printing. It was decided that the pupils could design whatever they wanted, as long as they used the OCS and worked in an iterative process. Before next meeting we produced the guide, which includes the material Rachel would need to plan the highway bridge learning activity (see B). At the following meeting the Rachel would give feedback to the guide and we would answer any question what she still had.

5.1.1 The Learning Activity Guide

The learning activity guide gives a straight forward, step-by-step way of planning the learning activity, since that was what the teachers in the Pilot Study expressed the need for (see 3.2.2). Rachel was encouraged to use the guide but plan the learning activity to fit into her specific context of teaching.

As discussed in terms of the literature, it is believed that some structure would improve the outcome of the learning activity (see 4.2.1). Therefore, we provided Rachel with a structure of six phases in a iterative learning activity. These phases were very much connected to the learning activity at hand, but was somewhat similar to some of the design models described by Martinez and Stager [2013]. In the learning activity guide a six phases iterative process was suggested (5.1). The guide contains the following six chapters:

1. What is a 3D printer - videos and knowledge about the technology.
2. What is the the working process like - Explanations of the iterative work process and instructions of how OCS works.
3. The design tools - guide to Tinkercad and REALvision

4. The design task - Material to introduce the design task to the pupils. Including a task description and videos.
5. Group work - How the pupils work on their design, and areas in need of extra attention.
6. Pitch - Presentation of work.

The learning activity goes through six phases, where four will be repeated in iterations. First the teaching activity starts with an introduction, including the following: 1) 3D printers, what they are and how they can be used, 2) The design tool, how to use it and avoid pitfalls, 3) the iterative working process and the OCS, and the fact that the pupils are not finished when they are finished with their first 3D print. After the introduction the pupils will enter the iterative process, during collaborative group work they will create their first design. Hereafter, the pupils will 3D print their object, because of the increased printer capacity one 3D printer is available for each group. Therefore, they will need to learn how to start a 3D print, while printing the pupils will calculate the price of the bridge. While the object is being printed, the pupils will calculate the price of materials, used to build the bridge of concrete in the real world. Afterwards, the pupils are ready to enter the testing phase, where they will test the strength of their design, by placing weight on top of it until it breaks. In the last phase they will use the OCS and place their broken design, and then evaluate how they could improve it on either or both parameters. The OCS could also give an idea of which factor to focus on, which they will use when re-entering the design phase. After having gone through the process a couple of times the iterations should have improved their design. The learning activity end with the pupils presenting their designs and work process.

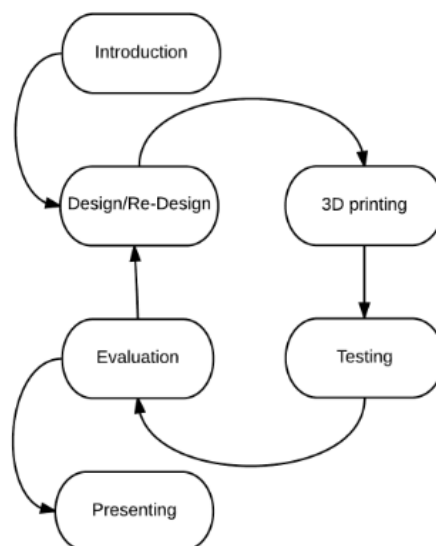

Figure 5.1: Figure showing the process the pupils will go through in the learning activity planned in the Field study.

We argue that designing a bridge through this iterative process is a good way of constructing a problem based learning activity with a 3D printer where the pupils can use a tinkering mindset. There are three main reasons for this: 1) We have the process in focus, 2) There is the right amount of constrains, and 3) The pupils learn the importance of failing.

Having the process in focus We argue that OCS also encourages the pupils to continuously improve their design through working in the iterative process. Furthermore we argue that this type of learning activity can support tinkering, since it is using several suggestions by Resnick and Rosenbaum [2013], for instance "emphasizing the process over the product" and "combining diving in with stepping back". This is done by putting emphasis on the iterative process in the introduction of the learning activity to the pupils. Furthermore, the OCS is expected to provide an opportunity for the pupils to step back and evaluate, and dive into the design process with new ideas.

The right amount of constrains The design task is to design highway bridges, but the task also adds some further constrains. The goal is to design a strong bridge with a low material cost, where two cars can pass over and four trucks under. These constrains are expected to have influenced the success of this learning activity. Constrains can be seen as limitations, however, they are not necessarily a limitation to creativity, in fact having the right amount of constrains in a problem solving task, can promote creativity since they create a problem which needs to be solved [Onarheim, 2012]. Figure 5.2 shows the perceived potential of creativity relative to the number of constrains. Between having too many constrains and having too few lies the *sweet spot of creativity* [Onarheim and Biskjaer, 2015]. However, the constrains in the bridge learning activity are flexible, meaning that the two constrains "low price" and "high strength", can be varied into a manageable size for each pupil. For instance, if the pupils find too many constrains they can simply start by focussing on one, on the other hand they can always improve their design to make it better than before.

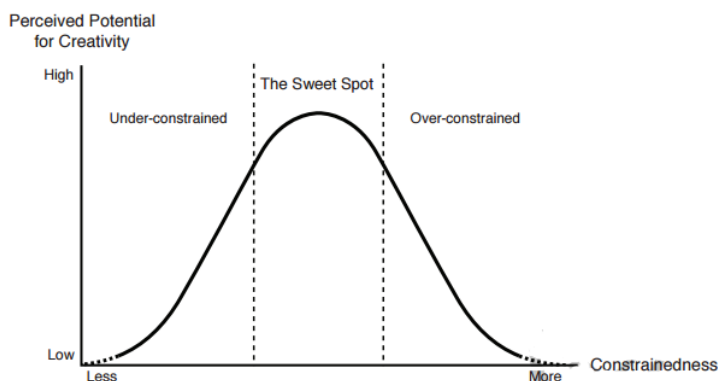

Figure 5.2: Figure showing how constrains effect the perceived potential for creativity [Onarheim, 2012]

During the learning activity the two axes on the OCS will be these two constrains. The thought is that the OCS will contribute with a visual representation of the problem they are solving and how well they are doing it, which will help the pupils evaluate their work and find out what to focus on for themselves. It is also believed that having constrains will make it easy to get started for the pupils. Furthermore it is believed that the activity will provide a low barrier for participation, but also chance to create sophisticated designs, which will support the pupils in developing a tinkering mindset [Vossoughi and Bevan, 2014].

The Importance of Failing In this learning activity the pupils are designing bridges and breaking them when testing. We know from the Pilot Study (see 3.2) and what Blikstein [2013a] refers to as "Keychain Syndrome" , that the object the pupils are designing influence their way of working. We argue that a bridge is a neutral object, which the pupils will not feel a strong sense of ownership towards. Therefore, we think they can collaborate on a solution instead of designing an object they want to bring home. Another advantage that we believe that that designing a bridge will have, is that the pupils are going to break it. When testing how much weight the bridge can hold, the pupils are learning something about the benefits of failing fast. Making drafts and that have failed attempts is an important part tinkering [Vossoughi and Bevan, 2014, p.24].

We argue that this will demonstrate the fact that failure does not have to be bad or shameful, but that it is in fact a chance to learn something. With the OCS at their disposal we also hope that it will be easier for the teacher to have a conversation about HOW and WHY their design failed, and what can be done to improve upon it. Furthermore, testing and interpreting on test results is also an important aspect of the STEM fields, and therefore this is an important part of the learning activity. The nature of the test means that the design not only should, but must, fail in order for the group to learn.

5.1.2 Data Collection

From the field study, data was gathered in the form of video recordings, pictures and field notes. The video recordings were primarily done in the stages of the process were the pupils were testing their designs or using OCS, since the evaluation of these systems is the focus on this field study. Both sources of data was collected by both researchers, and in total 32 pages of field notes and about 40 minutes of video recordings were collected. This is due to the fact that in the analysis, it is desired to find out what the general experience of the pupils designing bridges. For the last two days only eight pupils in total worked with the printers and made 3 different projects. The field notes was mainly written while being in the field.

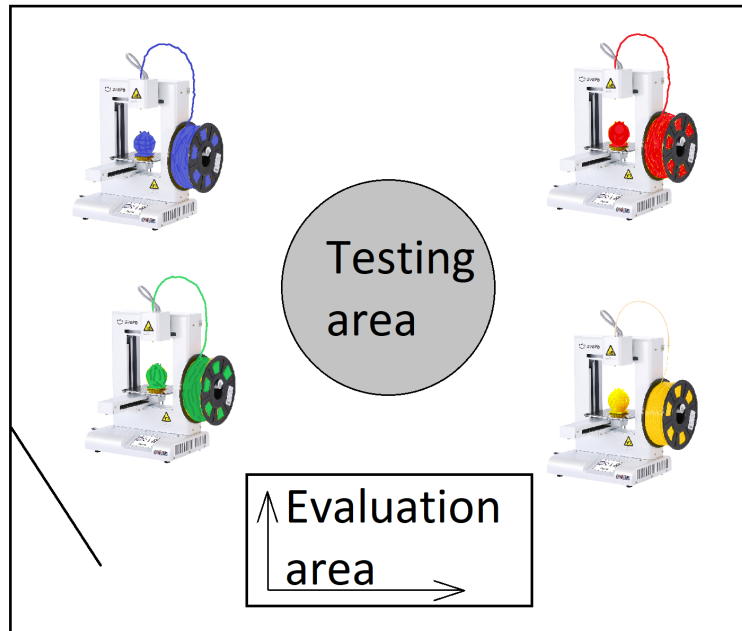

Figure 5.3: Figure showing the layout of the class room.

The field, A class room at Sønderbro skolen, four 3D printer, printing with different colours are placed in each corner, here the pupils design and printer their design. In the middle there are a "Testing Area" where weights are placed, at Rachel's desk the OCS are placed and here the pupils can evaluate their design (see figure 5.3).

In table 5.1 the amount of participants each day, and the type of project they worked on can be seen. For the first three days, three separate groups of pupils worked on the bridge project. When facilitating the bridge project Rachel followed the learning activity guide thoroughly. Of these initial participants, eight in total participated in working on projects they conceived themselves on the last two days. Of the eight that participated in these last two days four pupils participated both Thursday and Friday, one only participated Thursday, and three pupils only participated Friday (see table 5.1).

Day	Monday	Tuesday	Wednesday	Thursday	Friday
Project	Bridges	Bridges	Bridge	Self conceived	Self conceived
Pupils	13	11	13	5	7

Table 5.1: A table displaying how many pupils worked on different projects in the days observations were performed

Self Conceived Project In the last two days the pupils could decide for themselves what projects they wished to pursue as long as they could go through iterations or use the OCS. This resulted in three separate projects, designs of spinning tops, boats, and fidget toys. In this part of the learning activity the data gathering was different. Because of the low amount

of participants, and the variety between the projects, it was possible to follow the individual pupil's process closely. During these days more video recordings were made in the testing phase.

One pupil, hereafter referred to as Fred, decided to make spinning tops that could be started with a gear. This object was based on a design that was found online that was modified ¹. On the first day of this project, Fred worked on it individually. However, during the day another pupil would sometimes come in and discuss the design with him. Friday this pupil, hereby referred to as Mick, joined him, and they worked together throughout the day. Together they designed three new versions of spinning toys (see Figure 5.4) Five pupils in total worked on boats during

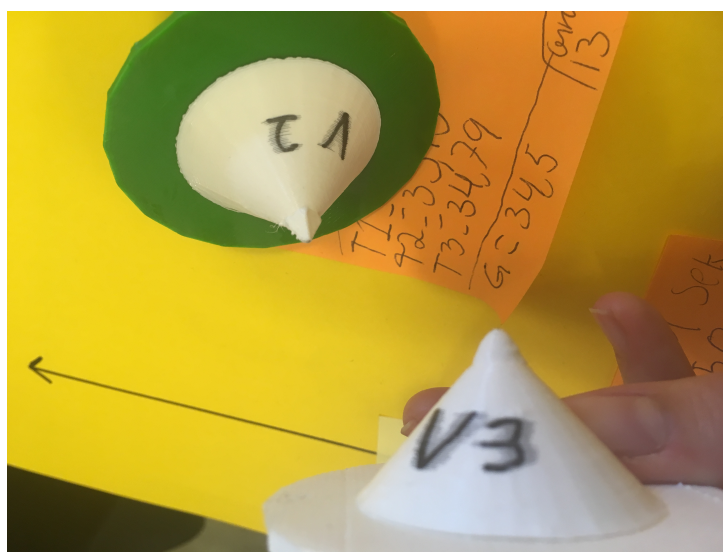

Figure 5.4: Two versions of spinning tops, a self conceived design task in the field study.

these two days, however, only one of them participated both days, with one participating the first day only, and two participating the last day only. In this project the boats were created entirely by the pupils themselves, and no models were used from other sources. The pupils tested if the boats could float and how much weight they could bear before sinking (see Figure 5.5).

Two pupils designed fidget toys, and both were present both days. We did not have written consent forms for these two pupils, so unfortunately no viderecordings were made of them working. Also these pupils did not use OCS in their design process, although they did go through an iterative process and seemed to have a tinkering mindset. However, the researchers chose to focus more on the spinning top and boat groups during the final two days.

¹<http://www.thingiverse.com/thing:1395135>



Figure 5.5: A boat is being tested, a self conceived design task in the field study.

5.1.3 Data Analysis

Since all data from this study is qualitative in its nature, a method for the analysis must be found within the qualitative analysis methods. Two separate analysis methods were used. A video review session was conducted, where the teachers would comment on some of the recorded video data [Jordan and Henderson, 1995a]. This was to assess the learning outcomes of using the OCS approach in the learning activity, and shed light on whether the pupils used a tinkering mindset within STEM fields. Furthermore, the five fold methods defined by Yin [2015] was also used to analyse the recordings and field notes in regards to 21st century skills, to investigate if the approach can also support development of these skills.

Video Review session A video review session was conducted to give an understanding of what the Rachel thought the OCS-supported approach contributed with in the learning activity. In a video review session the participants were presented to a video and asked to comment on the interaction [Jordan and Henderson, 1995a]. Normally it would be the people recorded who comment on their own interaction, however in this case no pupils participated, instead Rachel and Bruce participated in the session. According to Jordan and Henderson [1995a], participants can have different views on which parts of a video are relevant, and this can be used to get an insight into how these teachers view the recorded instances, in terms of: Learning outcomes, motivation of pupils, and benefits of testing and using the OCS. This will provide a more in depth understanding of exactly what these components contributed to the learning activity, and how the teachers used them to achieve the results and learning objectives.

Video ID	Topic	Design Object	Length [Min.Sec]
6Bridge_Ons	Testing	Bridges	0.15
27Boat_Tor	Testing	Boats	1.09
22Tops_Fre	Testing	Spinning Tops	0.28
7Bridge_Ons	OCS	Boats	0.44
14Tops_Tor	OCS	Spinning Tops	1.03

Table 5.2: Table showing which videos there was used in the recall session, their topic and their length.

Five videos were selected for the review session, three in which the pupils are testing and two in which the OCS is used to evaluate their design based on the test results. The session was expected to not exceed one hour. The videos were selected to be around a minute when this length of video existed, and to be a good representation of the situation (see table 5.2).

The review session was planned so the teachers would see one video at the time. Afterwards they would comment on the content and answer a couple of questions, depending on whether their comment already answering the question. Audio recording was started after the introduction, and the parts of the data which had valuable content were transcribed.

Five fold analysis The video database was compiled by giving each video a unique name, so they could be represented in a video log. After the videos were named appropriately, the video log was created in which a rough transcription of verbal interactions and events. Furthermore frames of the original video were added, to provide context. All the field notes were also digitised and details were added in order to elaborate on the context, fields notes the red coloured codes were created retrospectively. All data was finally compiled in one a spread sheet ready to be coded (see F).

The data was coded by the researchers together, and was coded after predefined categories. These categories consisted of the 21st century skills as defined by Microsoft [2012] (See C), the codes "Context", "improvements", and "Implemented improvements" were added. Finally the code "NA" was added to the data that did not seem to contain anything relevant. And example of the coding can be seen in 5.6. The Danish government entity CFU (Center For Undervisningsmidler, Translated: Center For Educational tools), has defined a list of 21st century skills that they promote throughout the Danish educational institutions [CFU, 2016]. These are built on the 21st century skills defined by Microsoft Partners in Learning [Microsoft, 2012], and consists of the following skills: 1) Collaboration 2) Knowledge construction, 3) Real World Problem Solving, and innovation 4) The use of Information and Communication Technologies for learning (Referred to as ICT in the following) 5) Self regulation 6) Skilled Communication (Referred to as communication in the following).

Over hele ugen har eleverne startet op i TC tutorial, det skal læren være forberet

336	Ons	Fac2	Fieldnotes	Eleverne tager fast i modellerne af biler og lastbiler (udprintet) som det første.	Problemsolving
337	Ons	Fac2	Fieldnotes	Eleverne er godt i gang, med tydelig besked om gruppearbejde	Kollaboration
338	Ons	Fac2	Fieldnotes	Randi underviser normalt 9 klasse over hele ugen har eleverne startet op i TC tutorial mode, det er læreren nødt til at vide at det er forkert.	Kontekst
339	Ons	Fac2	Fieldnotes		Forbedring

Figure 5.6: This is an example of the field notes taken when observing at Sønderbro Skolen

Instances where motivation seemed to be present, it was coded for the 21st century skill "self regulation" since motivation and self regulation are related [Ryan and Deci, 2000] [Bandura, 1993]. Situations where 21st century skills were not present, they were not code as "a missed chance", mostly these data chunks was code for context, since they describes the context of this learning activity.

After the codes were created they were counted to get an idea of which 21st century skills might be most profound in the data. It should be noted, however, that with qualitative data a high number of codes in itself does not entail a higher level of significance, as the importance of the different instances should also be considered. However, the amount of codes can still be a part of the understanding of the data. The amount of codes generated by each project can be seen in table 5.3.

	Spinningtops	Bridges	Boats	Presentations	Total
Problem solving	19	20	29	21	89
Collaboration	18	15	11	0	44
Self regulation	18	36	11	8	73
Knowledge Construction	14	32	12	4	62
ICT tools	5	0	0	3	8
Communication	3	15	0	11	29
Total	77	118	63	47	305

Table 5.3: A table displaying the amount of codes that each of the projects were responsible for.

5.2 Findings

5.2.1 Teachers Review Session

Through the video review session several interesting elements were found, the teachers know the pupils well which adds an extra dimension to the data. In the beginning the teachers were told to notice instances of learning or motivation and they focused on this a lot during the session. This section contains some of the important findings of the video review session.

The Learning Activity Through the learning activity the pupils were very motivated and Rachel explains that she did not have to do anything in particular to maintain their motivation. Bruce believes that one of the most important things for this learning activity to run smoothly and keep the pupils motivated is the amount of 3D printers. Being able to let the pupils be in control of the printer process and let them print whenever they are ready is very important, and something Bruce lacks in the learning activities that he normally taught. Rachel also mentioned how important the iterative process is for the learning activity, that the teaching happens when she guides them through the different phases. The test helps the pupils understand their design and using the OCS helps them set a course for improving it. When asked which role Rachel has in this learning activity the teachers answered:

Bruce: *A counselling role, to help guide him get things thought through.*

Rachel: *Well that was the intention, that he was the one that should do the thinking and come up with ideas of what to do next.*

VR Rachel and Bruce Time: 5:12

During the video review session the teachers was also asked which effect they believed having technology interested pupils had on the learning activity. In general they thought that it might have affected the interest for the 3D printers. But that everyone could have learned to design in Tinkercad and learned something from going through the process and using the OCS to evaluate their design. Bruce suggests that using this learning activity in a normal class situation the groups should be made so that there were some technology interested pupils in each group:

"It is relatable to when I started 3D printing with the entire 7th grade. Here some of the girls and those who were not tech nerds, would express that if it difficult to design, they would give up. Whereas, [the technology interested] will express that they will work through it and get it done. You can get around this by creating the groups such that there is at least one technology interested in each one"

VR Bruce: 27:48

Testing the design The teachers have the general opinion that testing is an important source of motivation. The two main reasons for why testing motivated the pupils was that it visualised the issues with the designs and that the results came relatively fast. When testing the strength of the bridges the pupils are highly motivated and Bruce says:

"Those boys are just finding the playfulness in it"

VR Bruce Time 1:10

. This implies that the pupils found testing the strength fun, however, it also turned strength into a relatable concept for the pupils. The teachers also believe that having the test visible in the middle of the classroom draws a lot of attention which increases the interest from the other pupils and also adds an element of competition. When testing the boats the set up was quite different, and here the teachers talked more about learning than motivation. They thought that test brought more learning to the pupils by helping them reflect and evaluate their design. One of differences in the two tests are that if they worked in groups or as individuals, and Rachel argues that working in a group would have contributed with more conversation and planning which, with the right guidance, would lead to more knowledge construction. After having watched the video where the pupils are testing the spinning tops the teachers state that these pupils are both motivated but also learns a lot from testing their designs. Bruce points out that explains the importance of working with meaningful relatable problems:

[They] I notice that they that their motivation increases, since they can both see what is going on and it makes sense for them that moment. I think that it is the fact that the test is short...

VR Bruce Time 12:16

Oresmian Coordinate System During the learning activity with bridges the OCS was placed on Rachels desk which made it visual for the pupils how their design was related to the others, which in turn gave the pupils the chance to compete with each other providing a motivational factor. The OCS also contributed with learning, Rachel expresses that she really liked using the OCS and that it was a great way to guide the pupils to solve their problems. However, the teachers also believed that the pupils get a better understanding of how a coordinate system works in general. By using the OCS the pupils are using math in real-world context which can help them get an understanding of a coordinate system.

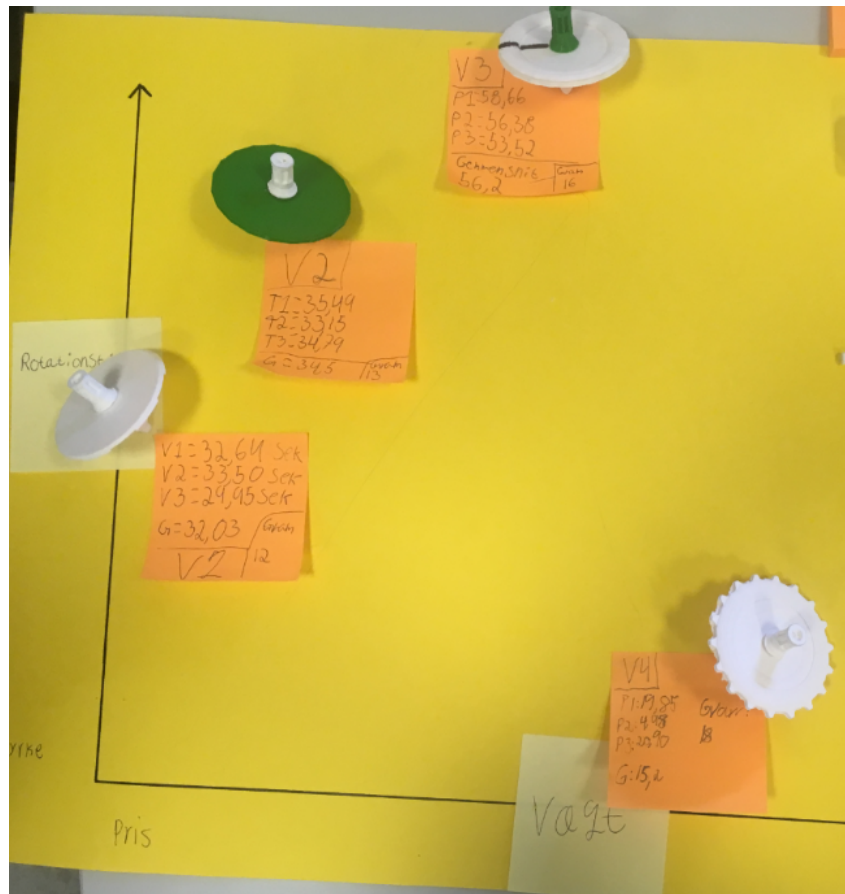

Figure 5.7: The Oresmian Coordinate System being used by the spinning top group. The x-axis refers to weight, and the y-axis to average spinning time of three measurements. Four different versions are placed on the coordinate system.

One of the most interesting knowledge constructions happens on the last video (see table 5.2) when Fred is placing the first two versions of spinning tops on the OCS. By having measured the spinning time and knowing their weight he finds that the heavier the spinning top the longer it will spin. In this situation Fred has decided which units were used on the axes, and he discovers a correlation which leads him to construct knowledge (see figure 5.7), not just evaluate his design as they do with the bridges. Bruce, who normally teaches Fred, says :

"I am not sure that Fred had seen that if he had not placed them in the coordinate system"

VR Bruce Time 18:27

5.2.2 21st Century Skills

The 21st century skills were all coded in the data. The code context was used to describe things such as, the amount of pupils, time, gender distributions, and which pupils had previous experience with 3D printing.

Collaboration The gathered data shows that pupils in general went through several instances of highly productive collaborative work, and this was coded for 44 times in the dataset. The pupils engaged both in peer-to-peer collaboration and pupil-to-teacher collaboration². In order to support good collaboration it is also believed that the group should not exceed three pupils, due to our own observations and statements from the teachers³.

During the bridge project pupils would collaborate well between classes, and it was noticed that older pupils would regard younger pupils as peers⁴. The layout of the classroom at this time also supported this type of collaboration, with a testing area in the middle of the classroom where pupils from all different groups would help each other perform the test, where some would hold the papers in place, and others would stack them on top of each other. Most bridges were so strong that the pupils also had to sit on top of them in order to make them brake, and in this case the pupils would use each other as support to make sure that they would not fall (see Figure 5.8). It is believed that this form of collaboration across the different groups were facilitated by the fact that there was only one testing area, and this is seen as an advantage since it becomes a major and fun event for the whole class during the learning activity⁵.

It was seen that Rachel was mostly a mediator for the group talks, and not just a transmitter of instructions or knowledge, and therefore it is even suggested that Rachel is almost more of a peer than a teacher to the pupils, since she communicates effectively with them on their level.

The nature of collaboration in the final two days of the week was very different from the first three days. This is believed to be mainly due to the fact that the pupils were working on different projects in different groups, and therefore little to no collaboration was seen between the groups. For the spinningtop project, Fred worked alone during the first day, and Mick joined him the next day after having shown interest in the project even though he was in another class. On the first day Fred relied somewhat much on one of the facilitator for testing, mostly because the test included starting the spinning top and a stop watch at the same time, which was easiest with two people. When Mick joined him, however, the facilitator hardly had to intervene at all. Fred and Mick had two different tests they did, and shared responsibility in both these. Also Fred

²Bro:173, 174, 318. Video:3, 15

³Bro: 23, 52, 67, 71

⁴Bro: 179

⁵Bro: 167, 170. Video: 6, 8



Figure 5.8: A situation of testing where it can be seen that many pupils all participate in the testing.

often took responsibility for writing down results from the test, and in general there was a quite high level of collaboration between the two pupils⁶.

⁶Top: 164, 168, 169 Video: 13, 15, 16, 20

In the Boat project the pupils did not have the same level of shared responsibility, and most pupils designed and tested their own boats without much shared responsibility with the other pupil's boats. The level of collaboration seen was mostly on a form where they helped each other with the test, and gave each other suggestions for their individual designs. Also these pupils relied a lot on the Rachel's feedback, and she mediated the conversations and the process⁷.

In general it is seen that this learning activity provided plenty of opportunities for higher levels of the 21st century skill collaboration, since the pupils have shown the collaboration skills of *negotiation, conflict resolution, agreement on what must be done, distribution of tasks, listening to the ideas of others, and integration of ideas into a coherent whole*. However, not all pupils achieve the higher levels of the rubric, as the pupils working on the boat project did not share responsibility, which means that these pupils only achieve the lower levels of collaboration. In the bridge project the pupils worked in the groups and made substantive decisions together, placing them at higher levels. Finally the spinning tops project is believed to be at the highest level of collaboration, since their work was very interdependent, especially in the testing situation where the outcome of the test depended on both of their efforts. Also the pupils seeming to be very much at the same wavelength, and showed very skilled collaboration throughout the project.

Knowledge construction In these learning actives the pupils needed to work in an iterative process which involves designing, testing and improving a design and knowledge construction was coded for 62 times. In order to do this the pupils needed to construct knowledge, and the process involves clear signs of both analysis, synthesis and evaluation. The purpose of the OCS it to give the pupils a tool which helps them evaluate their design, which it succeeded with in several cases. Often it opens up discussions and the pupils were able to understand how well their design fulfilled the demands, and it helped them focus on how they could improve it. They often used it to compare their design with others, and seemed to foster a positive competitive element. This is described in the following field note:

"Two pupils showed me on the coordinate system how and how much they had improved the price, and they were happy about it, and showed me on their own initiative"

Fieldnote, Bro: 140

Furthermore the OCS can also help the pupils to analyse their design, like when Fred discovers that when a spinning top increases in weight the spinning time also increases⁸. This lead Mick and Fred to the syntheses that heavier spinning tops would rotate for a longer time, which is a theory that was tested and verified with the third version. The fourth version of the spinning top was the heaviest, but also the slowest, and they had to evaluate why this spinning top did

⁷Video: 30, 31, 32

⁸Video: 14

not support their generated theory (see figure 5.7). Throughout the data there are examples of pupils making syntheses based on the knowledge and experiences gained by previous iterations and analyse and evaluate their design⁹. The following field note describes this:

"The pupils improve their designs by making holes in it. In order to make the bridge lighter [and therefore cheaper in materials]."

Fieldnote, Bro: 73

Therefore the OCS is a tool which is used by the teacher while the the pupils are constructing knowledge¹⁰. The test often provides the base of the analysis. This could be a situation where the pupils analyse a broken bridge to find its weak points or when a pupil discovers how the text on the side of his boat negatively impacts it's balance (see figure 5.9).

In order to get to the higher level of this 21st century skill knowledge construction needs to be the main focus. In this learning activity, knowledge construction is an important part, since solving the problem depends on which knowledge the pupils are constructing, by analysing, evaluating and synthesizing on their design and how well it performed in the test. However, the main focus is still to solve the problem given. In the highest level of knowledge construction there needs to be clear interdisciplinary goals, since this learning activity was done in a theme week there was no such goals. However, they needed to use math to calculate the price of the bridge, and they needed to use knowledge from physics to test and analyse the collapse of the bridge. Also the axes of the coordinate system themselves did provide two clear cut goals, one of them which was calculated using knowledge from geometry, and the other which was investigated through a physics experiment. Also it is believed that they constructed new knowledge which can be useful in other contexts in the future.

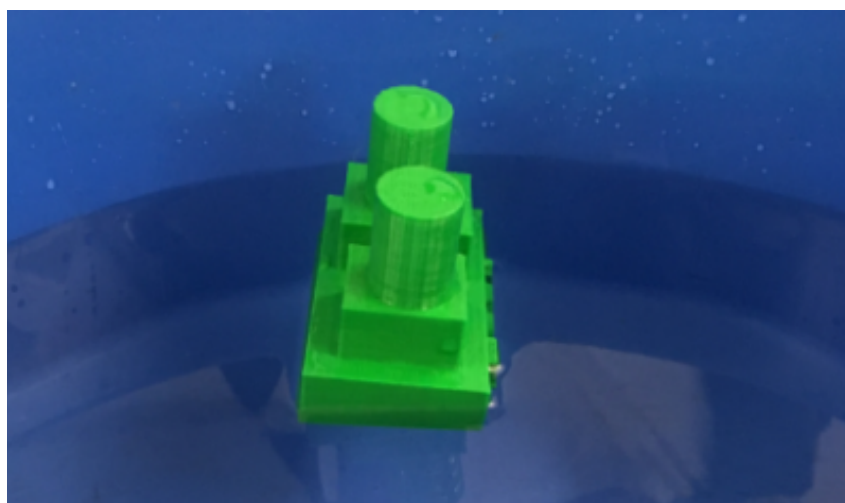

Figure 5.9: Green boat which float out of balance due to the text on the right side.

⁹Båd: 82, 83, 84 Bro: 138, 171, 172

¹⁰Båd: 88 Bro: 69, 153, 173 Video: 3

Self regulation One of the low levels of self regulation in the context of 21st century skills regards the fact that the learning activity should be long term. Since the bridge project was only during a single day, it might not seem that it is long term. However, it was a full day of about 5 hours, which which means that otherwise the learning activity would have been spread over several weeks. Also, the very core of the learning activity was to have the pupils go through many fast iterations. This means that in general there was still much possibility for planning during the project, and the OCS provided clear learning goals and success criteria which are also a important prerequisite for self-regulation¹¹. Therefore, we argue that the learning activity can be seen as long term which supports the lower levels of self regulation. With this in mind, the data was coded for self regulation 73 times.

It is found that the pupils did not necessarily plan their own work during the first iteration therefore it was necessary for Rachel to regulate and support the pupils at this time. It was found useful to set up a rule that the first 3D print of bridges should be started before lunch break, so the print would be finished afterwards. This rule was made to regulate the pupils to ensure that they would go through several iterations, due to an experience on the first day where the groups did not start printing until after noon which limited the number of iterations they went through. It seemed important for the Rachel to introduce the whole process of, designing, printing, calculating, and placing the design on the OCS the first time, so the pupils would know the process. However, it is seen that after the first iteration the pupils are given a much higher level of control over the process. For the later iterations pupils would be very independent, going through the entire process without much interference, and would manage the 3D printing process themselves¹².

The test itself seemed as a source of motivation, as it was generally deemed fun to do by the pupils, and this made it somewhat of a highlight in the project. For the later iterations the pupils were even given control over when they wanted to have a break, and could have a break whenever a print was started, and all calculations of price had been done. The pupils seemed to handle this very well, and would not "misuse it" by simply rushing through these steps to have a break sooner¹³. There are also signs of pupils modifying the goals of the learning activity slightly to a more personal style. Since both price and strength was measured, and placed on the OCS, some pupils focussed more heavily on one or another of these. However, some pupils were also somewhat discouraged at the fact that they believed that their peers' designs outperformed theirs to such a degree that they had no chance of catching up¹⁴.

During the last two days, the pupils were able to self-regulate to an even higher degree, probably because they knew how to work in an iterative process, and had experience with the 3D printer by then. The group that worked on the boats were, however, not that skilled when it came to self regulation, as Rachel had to mediate and control their process quite a lot compared to the other

¹¹Video: 7, 8, 14

¹²Bro: 180, 348

¹³Bro: 183, 351

¹⁴Bro: 343



Figure 5.10: An image of a match between two of the spinning tops models

groups¹⁵. This can be seen by the fact that the data from the boat project is almost entirely coded for self regulation when Rachel tries to get the pupils to self regulate, and not the pupils actively self regulating.

In these days the spinning top group showed a very high level of responsibility for their own project, and helped to set their own goals for their learning process along with Rachel and facilitators. The group would independently: 1) Use OCS for planning iterations 2) set up tests of each iteration by measuring weight and average spin time of each iteration 3) redo tests when something went wrong, for instance if the spinning top hit their hand when it was started 4) redesign a tournament in a different way than the facilitator had suggested because they thought it would give a better picture of which spinning top was best 5) They initiated the tournament without external regulation 6) and be in charge of writing down results from both the test and the tournament.¹⁶ All these actions could be seen as going even beyond the rubric for collaboration for 21st century skills, as the pupils not only worked towards a goal set by the teacher, but were able to set their own goals and pursue them in a structured way.

In general though it was seen that the OCS, but also the test itself, helped the pupils regulate their own process, while still being oriented towards a goal. The pupil's opportunity to revise their work based on feedback was in the very core of the learning activity, and therefore we also see this 21st century skill at a very high level throughout the week.

¹⁵Video: 30, 31, 32

¹⁶Top: 43, 69 Video:13, 14, 18, 20

Real-World Problem-Solving and Innovation In the guidelines for 21st century skills, a great emphasis is put on the fact that the problem that is solved should come from the real world and be implemented in the real world once it is solved. This means that none of the projects in the theme week do problem solving or innovation at a high level, based on this definition. However, we believe that the process the pupils were involved in was very similar to processes of problem solving and innovation in the real world. Even though the bridges and boats were only built as 3D printed models, and even though the spinning tops were never sold as a toy by the pupils, the pupils still went through a process of solving problems to achieve the desired results. It is also mentioned, but not in the coding rubric, that problem solving will lead pupils to: investigating different parameters of the problem; generating ideas; exploring different possible approaches; Testing the solution; and make iterative improvements to solve the problem [Microsoft, 2012]. With this in mind, the problem solving and innovation that we believe did find place in the class will be described, and this accounts for 89 codes.

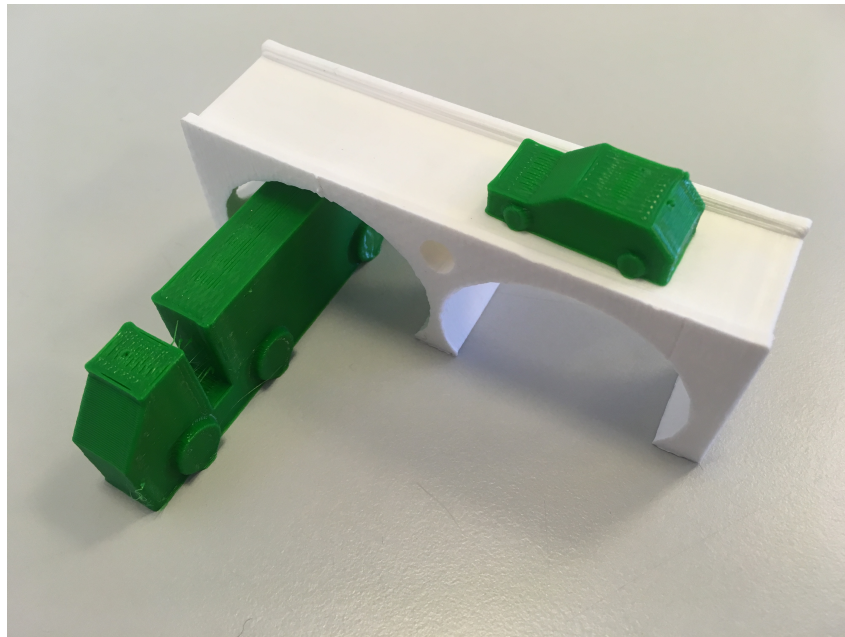

Figure 5.11: Version 1 of a Highway bridge, where two cars should be able to drive over, but there are only space for one.

Many pupils struggled with getting started on the first day, and therefore, the pupils were given virtual and physical models of the vehicles that the bridge should accommodate during the following days¹⁷. This meant that they could make sure that the bridge had the correct aspect ratio in different ways, and that different tools were used for problem solving. The nature of the bridge learning activity means that many problems became obvious to the pupils. For instance, when a bridge is printed and the 3D printed truck cannot pass under it, it becomes visible which problems should be solved (see figure 5.11). The OCS also ensures that the pupils can solve problems based on lessons that were learned by the failures of previous models, and we see examples of these iterations in the data¹⁸. During the presentations one of the pupils explained:

"The next time we tried to build two bigger individual columns, on on each side, and it was still very cheap ... And it could take about 200kilos. But the problem was that it would bend on the middle, which would be a huge problem if a truck had to pass the bridge..."

Pupil in Video 10

In the boat project, the problem solving is mainly focussed around the testing method. Because the balance of each boat is such an important aspect in testing them, much time is used to place the weights exactly right to maximize the capabilities of the boat. It is also discussed how to design boats, especially in terms of shape, that can float in a stable way. It is also discussed to remove unnecessary details such as, writing on the sides, and other decorative means, in order to create a stabile boat. Another problem that was solved in regards to the testing methodology of the boats, was that the boats when they had sunk once would often be full of water, and this

¹⁷Bro: 51, 63 Video 8

¹⁸Bro: 73, 172 Video 3

meant that the boat would sink instantly afterwards. After making this observation, boats were dried between each trial¹⁹.

The group who created the spinning tops solved a variety of problems in their process, some related to testing methodology, and some related to design. During the tournament the spinning tops did not initially hit each other within the arena, so the arena was tilted which solved the problem. However, this created a new problem as the spinning tops would sometimes fall outside the arena during a match. Therefore, one of the group members would hold his arms around the arena to ensure that this did not happen. This group also used the OCS for their problem solving as they noticed the correlation between weight and average spinning time, and used this information to create their further iterations where they increased the weight even more²⁰.

In general it can be seen that the process of problem solving has been followed by the pupils in different ways. Most of them encountered problems that made their design unable to meet the criteria set up by either the teacher or themselves, and therefore had to solve these through an iterative process. However, as previously discussed the pupils did not apply their solutions in a real world context, that had effect outside the classroom, and therefore does not score high in this 21st century skill, as it is defined in [Microsoft, 2012]. But during the teaching activity the pupils did not only solve a lot of problems, which are very similar to the real world, the last two days they also defined problems themselves.

The use of ICT for Learning The use of ICT tools was not the main focus of the learning activity, and therefore only eight codes for using the 21st century skills was generated. One of the reasons this is not coded for the use of ICT tools is that in this analysis the 3D printer was not considered an ICT tool. The pupils did use Chromebooks to create their designs through an online CAD program, but they did not use the communication potential of their technology, nor were there many instances of pupils seeking out knowledge online to get inspiration. An exception for this was the group who created spinning tops. They found the designs for the spinning tops online, and modified them in order to improve them. In general it seemed that the group who chose to modify existing designs were more motivated than the ones starting from scratch, maybe because they could rely on the existing functionalities of these model, and therefore get further. However, due to the small amount of pupils who chose this, and the generally low use of ICT it can not be generalised. It is also believed that the tasks could be modified in order to achieve a higher level of ICT skills.

¹⁹Video 27, 28, 30, 31

²⁰Top: 183, 185 Video 19, 22, 23, 24

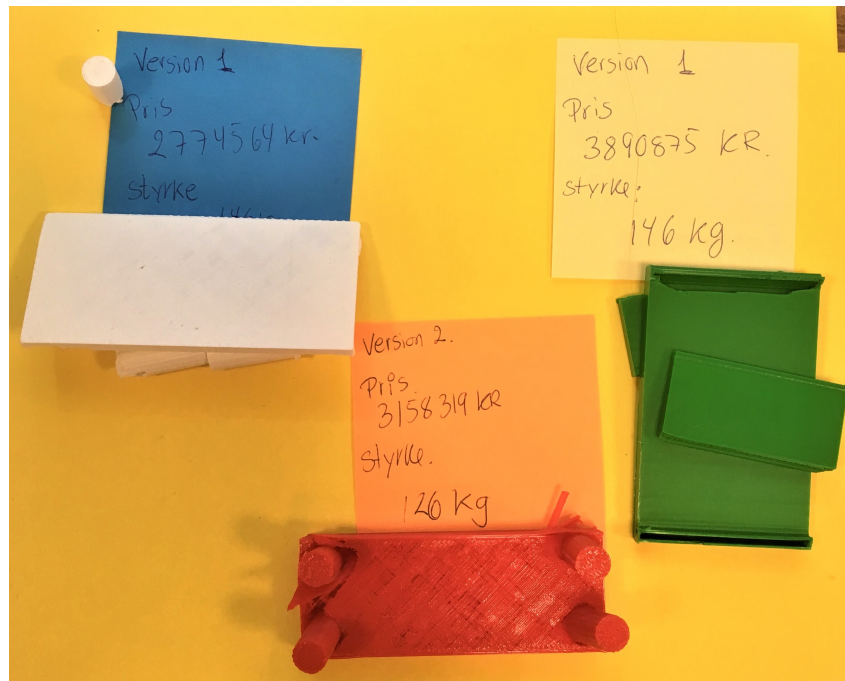

Figure 5.12: Version 1 Highway bridges from three different groups, placed on OCS with a post-it with data from strength test and price calculation.

Skilled Communication Before ending these learning activities the pupils were tasked with presenting their designs, which means that they all needed to communicate their work. When presenting their designs they often used the OCS and their 3D printed models. Examples of this is when the pupils finished their presentation of spinning tops with a demonstration. This means that the pupils communicate in more than one mode and use different tools to communicate their message.

This should in theory mean that the communication can be seen as multi-modal, due to Microsoft [2012]’s definition. However, the definition of multi-modal communication is made in regards to ICT tools, where OCS and 3D printed models are analogue and real world objects, and the closest some pupils came to use an ICT tool, was using a computer to show a new, not yet printed, boat design. Therefore, there can be some uncertainty about the pupils being multi-modal when communicating their work and ideas. However, the learning activities involved tests, which the pupils often used as supportive evidence which is an important part of skilled communication. By using OCS the pupils have documented how well their design performed in the test (see figure 5.12). Therefore, the pupils could communicate how their design had evolved, and the pros and cons of the different designs. In the highway bridge learning activity all bridges from all groups were placed on the OCS, which some of the pupils used as evidence for their design being the best.

However, this learning activity did not have a lot of focus on communication, and the pupils did not put a lot of work into this phase of the learning activity. This code was also only coded for 29

times. Also they did not present it to someone of interest outside of the school and therefore they did not get into a high level of skilled communication. It is believed that the learning activity about highway bridges could have been planned in a way that would have allowed more focus on the skilled communication, especially since the pupils did produce supporting evidence of their work.

Chapter 6

Discussion

The approach taken in this study was to conduct an exploratory Pilot Study, followed by a development of a solution, and culminating in a test of this solution and both these studies were qualitative in their nature, which is often the case when researching maker education [Vossoughi and Bevan, 2014]. This approach has been taken by other researchers who have studied similar topics [Smith et al., 2015], [Bekker et al., 2015].

6.1 Study Design

The exploratory approach provided some findings, that in themselves could be used for developing solutions to the various problems and barriers that were found. However, gathering data from many primary sources and spending many hours in the field gave the researchers a first hand understanding of what issues the teachers were facing. This approach of data gathering also gave rise to a large amount of interesting research topics. It was decided to delimit our investigation to 21st century skills, although many other pedagogical concepts could probably also be investigated. It was also chosen to focus on the more holistic aspect of the learning experience, rather than the more usability centered aspects.

In the observational study at Hals school we participated as action researchers, and the pupils almost regarded us as teachers. Even though this has its pitfalls in regards to performing objective research and collecting data, it did provide an in depth understanding of what it was like to be a teacher in this context. This experience is believed to be essential in for getting the idea

of the Oresmian Coordinate System (OCS) in the creative process.

The Pilot Study helped us as researchers to understand the teachers reality, or going down the U and connecting to the source as Scharmer and Senge [2009] would describe the process. When facing a problem there are various way to find a solution. People often follow their habitual patterns of action, and use the same approach to solve problems that are alike. This way of dealing with a problem is called downloading, since the project manager just downloads and uses a familiar approach which have worked before [Scharmer and Senge, 2009, chap.8]. Downloading is the direct way to solve a problem, however, in this project we took the long way, down the U (see figure 6.1), and got to know the reality in which our solution had to fit into before creating it. Going down the U underlines the importance of this deep understanding, and even though many sources describe a need for a balance between structured and free learning activities, we argue that the direct experiences of the Pilot Study contributed the necessary understanding to develop the OCS.

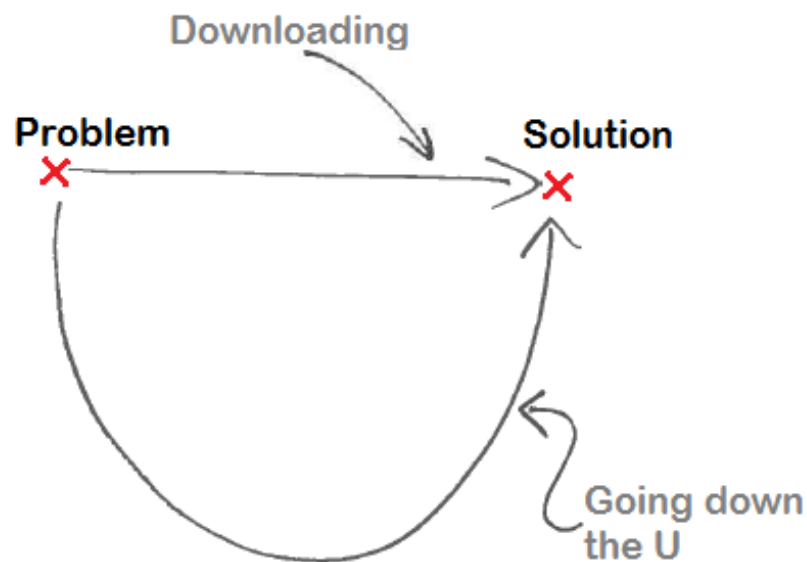

Figure 6.1: A sketch of two different approaches to solve a problem, downloading and going down the U.

6.1.1 Qualitative Methods

In the Field Study two methods were used to analyse the collected data, a video review session and Yin [2015] five fold method. This method was also used in the Pilot Study (see 3.1.2), here there were an explorative focus on the investigation. However, Yin [2015] method is flexible and therefore also useful in the Field Study, even though the analysis is more confirmatory with a more specific purpose.

A video review session was also used, which provided us with the type of rich data we hoped for. It worked quite well to have both teachers present, both because Bruce normally taught some of them, which provided us with rich data in relation to how the pupils normally worked. Rachel and Bruce also engaged in interesting conversations with each other, that provided rich data. However, we had planned for the teachers to pause the video during the session and encouraged them to do so, but they did not use that option. A more rigorous analysis approach could have been taken towards the video data gathered, for instance using more of the aspects described by Jordan and Henderson [1995b]. However, to investigate the learning outcomes and recognise instances of 21st century skills that level of detail was not deemed necessary. But this could provide more insight in exactly how the OCS approach supports these learning situations.

The study design also bore some resemblance of "Design Based Research". Design Based Research is a method used to educational research to conduct a study where an intervention is adapted iteratively to generate both theory about learning outcomes, but also to generate practical experiences that can be used for future learning activities [Barab and Squire, 2004]. This method also deals with the inherent "messiness" of learning activities:

"Learning, cognition, knowing, and context are irreducibly co-constituted and cannot be treated as isolated entities or processes"

Barab and Squire [2004]

The intervention in this study, being the introduction of 3D printers to the classroom, was adapted to a certain level, but did not go through that many iterations. The experiences from the Pilot Study was used to generate the learning activity that made use of the OCS which was in turn tested. This can be seen as being only one iteration of the intervention. However, this learning activity did go through certain iterations during the theme week, and was adapted through the first three days. The outcome of this study, however, both includes some theory regarding learning with 3D printers, and also practical experiences that can be used by educators. If more iterations cycles are made of the intervention, more theory and more practical experiences would also be generated, and the method of design based research could be used to obtain this knowledge.

6.1.2 21st Century Skills

In general the 21st century skills of: Knowledge construction, problem solving, self regulation, and collaboration were most commonly found in the gathered data. The coding rubric provided by Microsoft [2012], makes it easy to identify the different levels of 21st century skills. However, some of the definitions of these 21st century skills were somewhat not aligned with the learning activity. For instance, the use of ICT skills in this study was limited in the sense that Microsoft

[2012] defines them. The pupils would use a browser based CAD program, and a few would also find inspiration online to drive their ideas and design, and it can even be argued that the 3D printer itself is an ICT tool. Regardless 3D printers are a technology that the pupils are learning about, meaning that pupils deal with the "T" in STEM. The learning activity that was created is also very flexible, and we argue that it can easily be adapted to achieve these 21st century skills.

Other definitions of 21st century skills also exist [Greenstein, 2012], and coding for these might provide a different perspective on what 21st century skills were present. The definition of 21st century skills that was used because CFU (Center For Undervisningsmidler) had started a campaign encouraging teachers to use these definitions of 21st century skills. However, these might not be very suitable for work with 3D printing. This could be due to the fact that Microsoft [2012] defines these skills very much in terms of their own software products such as Bing, Skype, and Office365.

6.2 Attitudes Towards 3D Printing

During the Pilot Study, a rather broad scope was taken in regards to data gathering of attitudes, meaning that both positive and negative attitudes were included, particularly with the questionnaires. When collecting the data for the Field Study the focus was mainly on how Rachel introduced the task, and how the pupils tested and evaluated their designs using the OCS. This results in a somewhat biased collection of data, where positive experiences are over represented. Situations where pupils are using the OCS to reflect over their process are well documented, however, when pupils were demotivated or negative, it is not very well represented in the data. Furthermore, due to the focus of the coding, these instances would not be coded since they did not contain learning of 21st century skills, and was therefore only used sparsely in the analysis. One example is this field note, which was coded for "context":

"The girl-group became very demotivated by the printer problems. They were pretty upset by having to calculate the price on a new design before having tested their first design. The bridge was glued together for compensation."

Fieldnote, Bro:319

It is important to remember that situations like these did occur, some pupils where not focussed and some did not find the learning activity interesting. This analysis does show that by using the OCS approach it is possible to teach pupils a tinkering mindset within the STEM fields, and furthermore develop their 21st century skills. However, there are no focus on how problems with the 3D printers affected the pupils, or how motivated the pupils where for participating.

These aspects are investigated to a higher degree in the Pilot Study (see 3.2), and the use of a questionnaire makes it possible to assess the overall interest level of the pupils. However, during the Field Study, no additional data gathering was conducted, and therefore, it is not possible to measure reliably whether a higher level of motivation was present in that learning activity. However, the amount of uncontrolled variables, in this study, it would not be possible draw direct comparison even if the measuring device was the same.

Another explanation for the one-sided database can be the participating pupils and teacher. The Field Study was conducted during a theme week, and the pupils in our study have decided themselves that they wanted to work with "Technology and Game Development" instead of something else. This is likely to have an effect on the sample, being mostly technology interested boys, and therefore also on the data collected. It is also believed that Rachel had an influence on the learning activity, she took on a counselling role when teaching, and both when planning the learning activity and during the video review session she expressed her excitement about the OCS approach, and one example from the video reviews session is:

Yes, I have to say that I am very excited about that coordinate system and the way of working with them

VR Rachel Time 18:27

Clearly Rachel enjoyed this way of structuring a learning activity, she was capable of guiding the pupils through the iterative process and help them construct knowledge or solve problems, and furthermore is she used to teaching in STEM-fields. This means that both the pupils and the teachers might have a natural motivation which could be higher than in other samples. However, it was found both in the Pilot Study and mentioned in the video review session that the pupils who were not particularly interested in technology were able to use Tinkercad to create their own designs. But it can be hard to conduct research on a group of teachers and pupils who are not interested technology, and our data does not represent this group.

6.3 The influence of the Design Tool

In the Pilot Study there where a lot of focus on the design tool, all the teachers chose to let their pupils use Tinkercad, however they had different approaches of introducing it to them. Tinkercad was the most frequently coded item in the questionnaires and at Hals and Vadum it was observed how several of the pupils struggled to manage the design tool. Tinkercad makes it possible to design 3D figures, by dragging basis shapes from the right into the work plane (see figure 6.2). There is a wide ranges of possibilities for manipulating and combining these shapes into personal designs. When observing at Hals it was seen that the pupils could drag and drop

objects on to the workplane with ease, whereas they struggled when using the functions placed in the menu, the small grey buttons in the top right. Another problem that was observed was that the pupils sometimes and forgot to check their design from multiple angles which lead to hovering objects that can not be printed (see figure 6.3). Even though these observations were made about the usability of Tinkercad, the design tool is still considered simply, especially when considering professional CAD tools. Furthermore, the pupils were observed in a somewhat early stage of learning to use it, and it should be noted that all pupils could design something and get it 3D printed.

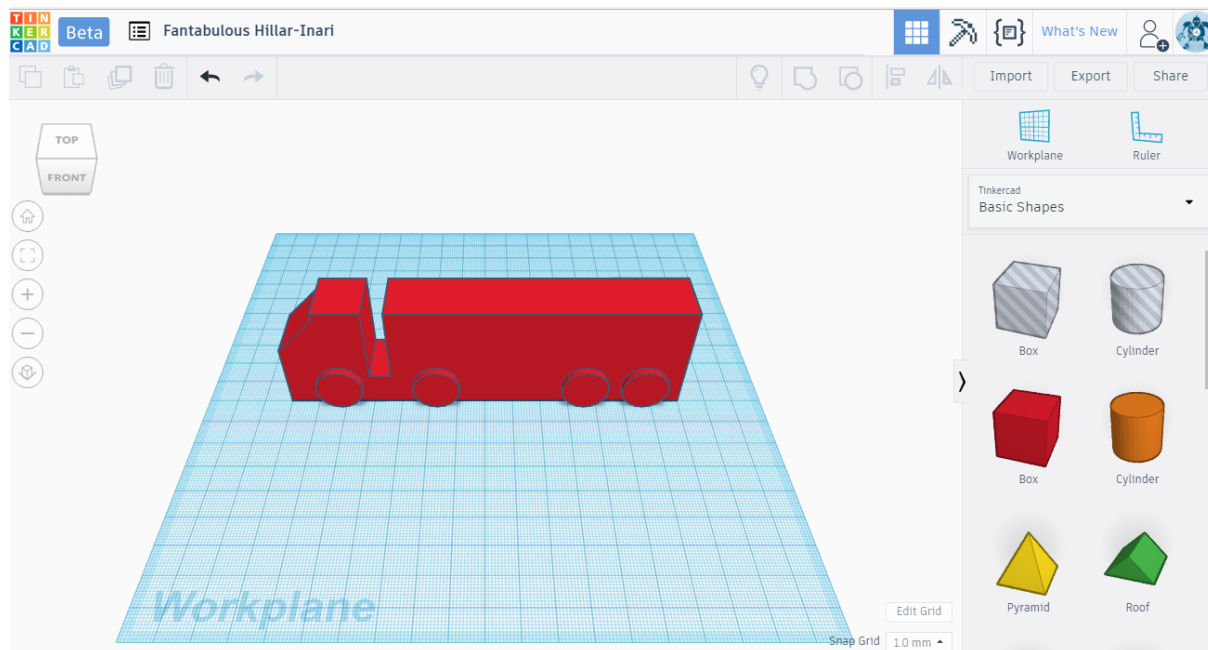

Figure 6.2: The layout of Tinkercad, showing the interface in which the pupils would design their objects.

One of the aims of this study is to support pupils and teachers in their first uses of the 3D printing technology. Learning Tinkercad, or another design tool, is without doubt a part of that. However, we argue that for introduction purposes a design task should not depend on a high level of skills with the design tool. At Hals the pupils designed mobile covers, and if their design was not measured correctly the cover would not fit on the phone. Therefore, in this learning activity it was necessary that they pupils had at a certain skill level in the design tool, in order to create a functional design. At Sønderbro skolen something quite different was observed when the pupils designed bridges. Figure 6.4 is an example of an bridge designed by pupils with somewhat limited skills in Tinkercad. The piers are in different sizes and not aligned, however the pupils managed to design, 3D print, test, evaluate, and improve their design through several iterations. The pupils observed at Sønderbro skolen also needed help in Tinkercad, however we argue that their lack of skills in the design tool did not limit their participation in the other parts of the learning activity. We also argue that this is one of the reasons why this learning activity, and designing bridges, can be suitable for introducing the pupils the 3D printing technology,

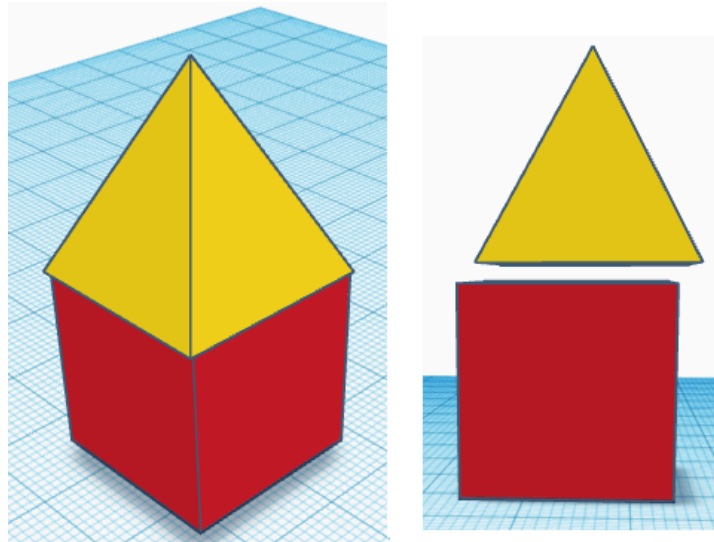

Figure 6.3: An example of the importance of looking at a design from more angles.

because understanding the design tool becomes a natural part of the learning activity. This also underlines the importance of choosing the right design task for the pupils in combinations with the structure of the learning activity. And even though the two observations can not be compared directly, due to the number of complex variables, it was observed that when a bridge design fails it motivated the pupils to re-design it and improve it and when the mobile covers failed it de-motivated the pupils by creating a problem the pupils would rather be without. It is important to note that these observations only regards introductory learning activities, and that learning activities that rely on more advanced knowledge about the design tool can be facilitated later in the process. This can also be relevant in regards to flow state theory, which states that flow state can be achieved when the optimal relationship between ones skill level and the difficulty of the task is present. [Barret, 2010]. Therefore, as pupils increase in design skill over time, more challenging design tasks can be given.



Figure 6.4: An example of a bridge created by pupils with a low skill level in the design tool.

6.4 The Oresmian Coordinate System

During the field test of the OCS there were seen signs on that depending of the units on the axes the learning outcome changes. During the bridge and boat project, the OCS was used to set a direction for tasks that involved optimising a product. This meant that both axes can be viewed as a goals, where the pupils could choose which goal they wanted to pursue when, and how they wanted to achieve it.

However, for the spinning top project there was a significant difference. The pupils who worked on this project wanted to create the best battle spinning top, and used the OCS for development along the way, and used a tournament as the final test. This meant that the pupils had to create hypotheses about which measurable aspect of the spinning tops might make it best for a battle situation. The hypothesis that they generated was that the spinning time might be one of the aspects that would matter in a battle situation, but they still had to work out what other variables could affect this. They ended up hypothesising that weight could affect the spinning time. This meant that the coordinate system in this regard ended up being a visual representation of the dependent variable spinning time, and the independent variable weight. This means that in this case the OCS was used to test a hypothesis about how two variables depend on each other. In this case only one axes would describe the goal, whereas the other axis described an aspect of the object that could be manipulated through the design, and through that the goal could be achieved. In the case of the bridges, where both axes were goals, a good design would be optimised by scoring high on both parameters. Where one approach lets pupils investigate how two physical variables have a correlation, the other tasks ask pupils to try and "cheat" the correlation that might exist between price and strength if the bridge is not designed efficiently. This opens up for a discussion about what coordinate systems are used for in other contexts. A coordinate system, or other types of charts, are often created to achieve an overview over data that would otherwise be hard to interpret for a human. The chart used in this case could be described as a scatter plot, and can be used to try and notice patterns in the data. As a teacher the goals of the learning activity can be planned by manipulating the axes, and by making the pupils see whatever patterns are present within the OCS. In regards to the spinning top project, the pupils here created a spinning top that did not follow the pre-conceived pattern, and concluded that this was most likely due to the fact that the spinning top had spikes in it and therefore was different from the rest. By going through this process the pupils are also explaining outliers, and reflecting on why they might break the pattern.

In in this study the OCS mostly supports STEM learning activities, and at least as it was used within this study, did not support STEAM (Science, Technology, Engineering, Arts, and Math) learning. Since it may be a challenge to measure art on a objective scale, it may be hard to have an "art" axis on the coordinate system. However, art does sometimes include problem

solving, and to achieve an artistic vision it is sometimes necessary to achieve more concrete goals. Therefore, the OCS might be used as a tool in some parts of an artistic process.

Even though, having clear predefined goals, and some structure, can be seen as opposite to tinkering [Resnick and Rosenbaum, 2013], we argue that it is necessary for when introducing the technology and the approach. The pupils would adjust their designs, and have a playful and exploratory approach to the learning activity. It is also argued that the pupils who worked on the spinning tops project achieved engineering as described by Martinez and Stager [2013] since they were connecting their direct experience of tested the spinning tops, with several hypotheses about physics and science. Even though this was the only project where it was clear that an engineering process was achieved, it was confirmed by the teachers that the OCS supported the pupils in achieving the engineering process. Furthermore, the teachers also confirmed that the pupils were having fun in the learning activity, which is also one of the aspects that can support a tinkering mindset, since tinkering is connected to play [Martinez and Stager, 2013].

The OCS was created in an attempt to try and create a compromise between structure and openness. Whereas, Resnick and Rosenbaum [2013], Martinez and Stager [2013], and Papert [1993], places a great emphasis on free tasks, later research has posed that some structure is needed, especially in school contexts [Smith et al., 2015], [Iversen et al., 2015], [Bekker et al., 2015], and finally Onarheim [2012] states that the right amount of constrains can promote creativity. As we do observe tinkering as a part of the activities that took place during the Field Study, this indicates that the coordinate system might provide a good level of constrains for the learning activity. The pupils that participated in the Field Study were mostly new to 3D printing, but already during the week it was seen that they could work more and more independently, and self-regulate their tinkering activity. As Vossoughi et al. [2013] points out there is also important distinctions between school activities, and other activities. So far the use of OCS has only been testing in a school setting, and therefore it has also been designed to accommodate certain curriculum standards, and the teachers role in a school setting. The OCS was seen to promote conversations about the process that the pupils went through, and was used by Rachel to guide these conversations. This might provide the possibility to provide praise for pupils process, rather than their end result or their intelligence. Mueller and Dweck [1998] argues, based on the results of six studies, that providing praise for work, effort and persistence might promote achievements in a more constructive way, than praising for instance intelligence. The results of this study indicate that the OCS might be able to support this type of praise, as it focusses heavily on the process.

Chapter 7

Conclusion

In this study we investigate how 3D printers are introduced in educational settings. To study this phenomenon, a Pilot Study was conducted in which qualitative data was collected from observations, interviews, and questionnaires and hereafter analysed. From the Pilot Study it was found that the lack of printing capacity posed threats towards the motivation of the pupils. Furthermore, it was found that the teachers believed that the 3D printers could be used for teaching STEM fields, however, evidence showed that some teachers had a hard time planning these learning activities. Instead the teachers had somewhat loosely defined learning goals, where the pupils would design pretty objects which did not have a high learning outcome. Therefore, a solution to help teachers introduce 3D printing with clear learning goals was developed.

Through a creative idea generation, the idea of the Oresmian Coordinate System (OCS) was conceived and should help the pupils evaluate their design. The OCS is a way of visualising how a design performs in relation to the goals/propose of the design, which should encourage the pupils to re-design and improve their design through an iterative process. The OCS makes evaluating a visual and important part of the 3D printing process and demands that the pupils reflect and put their thought about their design into words.

After the idea was conceived, the OCS was tested during a theme week. The learning activity was planned in collaboration with a teacher and in the first three days the three different groups of pupils would use the OCS to design strong highway bridges for a low cost through an iterative process. To achieve this it was necessary to increase the printing capacity, to have one 3D printer per group. The pupils would use skills from the STEM field to calculate the price of the bridges and measure its strength. Furthermore it was found that the pupils learned the 21st century skills of collaboration, self regulation, problem solving, and knowledge construction during the learning

activity. It was also found that the increased focus on the process of developing designs, that the OCS contributed to, would keep the pupils more motivated and interested during the week. The results that were found indicates that the OCS can be used as a means for achieving both a tinkering mindset, but in some cases also to teach engineering. The OCS seems to provide enough constraints to fit into a school setting, but enough freedom to achieve a personally meaningful process.

Chapter 8

Perspectivation

Besides from OCS, a growing number of guides on how to conduct learning activities with maker technologies exists [Martinez and Stager, 2013], some make use of processes that promote design thinking and reflection [Bekker et al., 2015], [Smith et al., 2015]. These seem to promote mostly activities related to industrial design and architecture, and will introduce concepts that can train children to think of design through this scope. The focus on this study, has been using the OCS for a STEM learning activity, and it seems to foster learning well within these fields.

The focus of this study has also been 3D printers, whereas the design thinking approaches mainly makes use of electronic toolkits [Smith et al., 2015] [Bekker et al., 2015]. Whereas STEM concepts do seem to be important to the design thinking approaches, it seems that the STEM fields are more used as a means to achieve the desired results of the design task. Evidence suggests that the OCS can be used to support learning that incorporates design, in order to investigate natural phenomena, such as mechanical designs of bridges and spinning time of spinning tops. Common for both design thinking approaches, and the approach taken in this study, is the attempt to balance a free learning activity with clear goals and directions. Furthermore, both approaches aim to teach a variety of 21st century skills. As more approaches like these become available, it becomes easier for educators to teach the topics they wish, with a variety of different maker technologies.

In future work we hope to develop and test a broader range of projects that can encompass the OCS. With the knowledge we have now a new learning activity guide is developed and can be seen in Appendix B. Furthermore, pedagogical patterns might be used as an effective means of sharing approaches such as the OCS. An important distinction between pedagogical patterns and learning activity guides, is that a pedagogical pattern is a flexible teaching technique that

can be used for teaching a variety of different topics. Therefore, a pedagogical pattern also provides the teachers with the opportunity to adapt the pattern to their own style of teaching [Eckstein, 2001]. The OCS was from the beginning defined as a flexible approach, that could be used for many projects including maker technologies, but it is also believed that it could be used within the scope of other educational fields. However, before a teaching technique can be called a pedagogical pattern, it needs practical testing in many contexts [Eckstein, 2001].

Bibliography

- Deborah E. Allen, Richard S. Donham, and Stephen A. Bernhardt. Problem-based learning. *New directions for teaching and learning*, (128), 2011. 40
- Albert Bandura. Perceived Self-Efficacy in Cognitive Development and Functioning. *Educational Psychologist*, 28(2):117–148, 1993. 38, 39, 58
- Sasha Barab and Kurt Squire. Design-based research: Putting a stake in the ground. *The journal of the learning sciences*, 13(1):1–14, 2004. 75
- Terry Barret. The problem-based learning process as finding and being in flow. *Innovations in learning and teaching international*, 47(2):165–174, 2010. 38, 39, 79
- Tilde Bekker, Saskia Bakker, Iris Douma, Janneke van der Poel, and Koen Scheltenaar. Teaching children digital literacy through design-based learning with digital toolkits in schools. *International Journal of Child-Computer Interaction*, (5):29–38, December 2015. 47, 48, 73, 81, 84
- Paulo Blikstein. Digital fabrication and making in education: The democratization of invention. *FabLabs: Of machines, makers and inventors*, 4, 2013a. 4, 53
- Paulo Blikstein. Digital fabrication and ‘making’ in education: The democratization of invention. *FabLabs: Of machines, makers and inventors*, 4, 2013b. 9, 10, 11, 39, 40, 141
- CFU. 21 century skills, 2016. URL <http://info.21skills.dk/>. 57
- Create it REAL, 2016. URL <http://www.createitreal.com/index.php/about-us>. 10
- Jutta Eckstein. Pedagogical patterns: Capturing best practices in teaching object technology. *Softwarefocus* 2001, 2001. 85
- Laura Greenstein. Assessing 21st century skills. *A Guide to Evaluating Mastery and Authentic Learning*. Thousand Oaks, California: Corwin Sage Company, 2012. 10, 76
- Søren Hansen and Christian Byrge. *Kreativitet som uhæmmet anvendelse af viden*. Frydenlund Academic, 2013. 42, 43, 44
- Ole Sejer Iversen, Rachel Charlotte Smith, Paulo Blikstein, Katterfeldt Eva Sophie, and Janet Read. Digital fabrication in education: expanding the research towards design and reflective

- practices. *International Journal of Child - Computer Interaction*, 5(1-2):1–2, 1 2015. ISSN 2212-8689. doi: doi:10.1016/j.ijcci.2016.01.001. 9, 47, 81
- Brigitte Jordan and Austin Henderson. Interaction analysis: foundations and practice. In *The Journal of the Learning Sciences* Jordan and Henderson [1995a], pages 39–101. 56, 87
- Brigitte Jordan and Austin Henderson. Interaction analysis: Foundations and practice. *The journal of the learning sciences*, 4(1):39–103, 1995b. 75
- Vasilis Kostakis, Vasilis Niaros, and Christos Giotitsas. Open source 3d printing as a means of learning: An educational experiment in two high schools in greece. *Telematics and Informatics*, 32:118–128, May 2014. 10, 40
- Sylvia Libow Martinez and Gary Stager. *Invent to learn: Making, Tinkering, and Engineering in the Classroom*. Constructing Modern Knowledge Press, 2013. 9, 10, 40, 50, 81, 84
- Microsoft. *21CLD Learning Activity Rubrics*. Microsoft Partners in Learning, 2012. 40, 57, 68, 70, 71, 75, 76, 135, 136, 137, 138, 139, 140
- Claudia M. Mueller and Carol S. Dweck. Praise for intelligence can undermine children’s motivation and performance. *Journal of Personality and Social Psychology*, pages 33–52, 1998. 81
- Helga Negendahl and Anders Bod Lund. Project work during internships. 2016. 16, 17
- Balder Onarheim. Creativity from constraints in engineering design: Lessons learned at coloplast. *Journal of Engineering Design*, 23(4):323–336, 2012. 52, 81, 89
- Balder Onarheim and Michael Mose Biskjaer. Balancing constraints and the sweet spot as coming topics for creativity research. *Creativity in design: Understanding, capturing, supporting*, 2015. 52
- Seymour Papert. *The Children’s Machine: Rethinking School in the Age of the Computer*. Basic Books, Inc., New York, NY, USA, 1993. ISBN 0-465-01830-0. 9, 40, 81
- Seymour Papert and Idit Harel. Situating constructionism. In Seymour Papert and Idit Harel, editors, *Constructionism*, chapter 1. Ablex Publishing Corporation, Norwood, NJ, 1991. URL <http://www.papert.org/articles/SituatingConstructionism.html>. 9, 39, 40
- Mitchel Resnick and Eric Rosenbaum. *Design, make, play: Growing the next generation of STEM innovators*, chapter 10, page 163. Routledge, 2013. 9, 10, 39, 52, 81
- Richard M. Ryan and Edward L. Deci. Self-determination theory and the facilitation of intrinsic motivation, social development, and well-being. *American Psychologist*, pages 68–78, 2000. 38, 39, 41, 58
- Claus Otto Scharmer and Peter M Senge. *Theory u: Leading from the future as it emerges*. 2009. 74, 145

Rachel Charlotte Smith, Ole Sejer Iversen, and Mikkel Hjorth. Design thinking for digital fabrication in education. *International Journal of Child-Computer Interaction*, (5):20–28, November 2015. 10, 40, 47, 48, 73, 81, 84

Systematic. Momo. URL <https://da.systematic.com/library-learning/loesninger/by-name/momo/>. 141

Shirin Vossoughi and Bronwyn Bevan. Making and tinkering: A review of the literature. *National Research Council Committee on Out of School Time STEM*, pages 1–55, 2014. 9, 10, 40, 53, 73

Shirin Vossoughi, Meg Escudé, Fan Kong, and Paula Hooper. Tinkering, learning & equity in the after-school setting. In *annual FabLearn conference. Palo Alto, CA: Stanford University*, 2013. 81

Robert K Yin. *Qualitative research from start to finish*. Guilford Publications, 2015. 14, 15, 17, 18, 19, 21, 22, 56, 74

List of Figures

1.1	The Ideawerk Speed, a 3D printer developed in collaboration between Create it REAL and Weistek	11
2.1	The location of the schools in the project.	13
3.1	A model of the different sources of data used for triangulation	16
3.2	Examples of field notes taken from Hals	17
3.3	An example of a reply to question F in the questionnaire. Transcriptions and translations are added.	19
3.4	An example of (From top to bottom) Raw data from the questionnaire, the coding of the transcription, and the code description	20
3.5	Sketch showing how data chunks are gathered in codes. How codes are gathered in higher level codes and how higher level codes are gathered into themes.	21
3.6	A picture taken of the reassembling phase of the interview data	21
3.7	Phone recording a object being 3D printed while standing in a 3D printed object.	24
3.8	A blue cover with numbers and a white Phone stander with the logo and name of a E-sport team.	25
3.9	The evolutions of a design. Note that the camera hole is placed on the wrong side on the design closest to the Phone.	26
3.10	Design fails because of support, after this the pupils refrained from using support for future covers.	28
3.11	Pupil expressing that her favorite object was a Justin Bieber key chain	39

4.1	The idea generation was facilitated by a slide show, this is one of the tasks the participants was asked to do.	44
4.2	How all the idea post-its was put on the table to help the participants generate ideas.	46
5.1	Figure showing the process the pupils will go through in the learning activity planned in the Field study.	51
5.2	Figure showing how constrains effect the perceived potential for creativity [Onarheim, 2012]	52
5.3	Figure showing the layout of the class room.	54
5.4	Two versions of spinning tops, a self conceived design task in the field study.	55
5.5	A boat is being tested, a self conceived design task in the field study.	56
5.6	This is an example of the field notes taken when observing at Sønderbro Skolen	58
5.7	The Oresmian Coordinate System being used by the spinning top group. The x-axis refers to weight, and the y-axis t average spinning time of three measurements. Four different versions are placed on the coordinate system.	61
5.8	A situation of testing where it can be seen that many pupils all participate in the testing.	63
5.9	Green boat which float out of balance due to the text on the right side.	65
5.10	An image of a match between two of the spinning tops models	67
5.11	Version 1 of a Highway bridge, where two cars should be able to drive over, but there are only space for one.	69
5.12	Version 1 Highway bridges from three different groups, placed on OCS with a post-it with data from strength test and price calculation.	71
6.1	A sketch of two different approaches to solve a problem, downloading and going down the U.	74
6.2	The layout of Tinkercad, showing the interface in which the pupils would design their objects.	78
6.3	An example of the importance of looking at a design from more angles.	79
6.4	An example of a bridge created by pupils with a low skill level in the design tool.	79
D.1	An example how a lesson plan named 'Design and Teas a Planflute' and which skills the pupils will learn or use in order to complete it are visualised on a radar chard.	142
D.2	The horizontal tiles design which was chosen in favour of the wide tile design	144

List of Tables

3.1	A table showing the instances of data collection. Note that no observational data was collected from Sønderbro or Højvang.	15
-----	--	----

3.2	Overview of the different themes in the Observation analysis and which Codes were combined.	23
3.3	A table describing how the themes were created from higher level codes.	29
3.4	A table showing how the theme teaching methods was made from the codes.	30
3.5	A table describing how the learning outcome theme was created.	32
3.6	A table showing how the Pupil's attitude theme was created	33
3.7	A table describing how the Learning processes and outcomes theme was created	35
3.8	A table describing how the printed objects theme was created.	36
5.1	A table displaying how many pupils worked on different projects in the days observations were performed	54
5.2	Table showing which videos there was used in the recall session, their topic and their length.	57
5.3	A table displaying the amount of codes that each of the projects were responsible for.	58

Appendix A

Article for EDULEARN 2017 Conference

In the following, an article that is to be published at the 2017 EDULEARN conference is presented. The article is based on the same work as the rest of the report, and it will be presented by Anders Bod Lund, and Helga Negendahl Madsen at the conference on the 3rd or 4th of July 2017. On the following page a co-author statement for the article is included.

Author Statement

Paper title: Barriers and Opportunities for 3D printing in Danish Schools: A Qualitative study

Publication outlet: EDULEARN17, the 9th annual International Conference on Education and New Learning Technologies

List of authors: Helga Negendahl Madsen, Anders Bod Lund, Dorte Hammershøi, Thomas Ryberg

Scientific contribution of:

Helga Negendahl Madsen: By facilitation of several workshops on 3D printing for education, Helga Negendahl Madsen defined the purpose and focus of this study. Helga Negendahl Madsen planned, conducted, and analyzed data from: field studies, interviews, and questionnaires. Helga Negendahl Madsen planned and facilitated a creative idea generation, in which an approach for teaching using a 3D printer was developed. This approach was dubbed the "Oresmian Coordinate System", and this approach was tested by Helga Negendahl Madsen in further field work. Helga Negendahl Madsen has read the paper in its entirety, suggested changes, and approved the final version.

Anders Bod Lund: By facilitation of several workshops on 3D printing for education, Anders Bod Lund defined the purpose and focus of this study. Anders Bod Lund planned, conducted, and analyzed data from: field studies, interviews, and questionnaires. Anders Bod Lund participated in a creative idea generation, in which an approach for teaching using a 3D printer was developed. This approach was dubbed the "Oresmian Coordinate System", and this approach was tested by Anders Bod Lund in further field work. Anders Bod Lund wrote the draft version of the paper and revised according to comments by co-authors and anonymous reviewers. Anders Bod Lund has read the paper in its entirety, suggested changes, and approved the final version. Anders Bod Lund was had contact to the Municipality of Aalborg, through whom we had contact to the schools. Furthermore, Anders Bod Lund had contact with Create it REAL who supplied the 3D printers for the project.

Dorte Hammershøi: Dorte Hammershøi helped define the scope of the reported study, and identify relevant aspects of the study. Dorte Hammershøi took part in discussions of the methodology, results and interpretations in the study. Dorte Hammershøi reviewed the draft paper, read it in its entirety, proposed changes, and approved the final version

Thomas Ryberg: Thomas Ryberg helped define the scope of the reported study, and identify relevant methods for data gathering and analysis. Thomas Ryberg took part in discussions of the methodology, results and interpretations in the study. Thomas Ryberg reviewed the draft paper, read it in its entirety, proposed changes, and approved the final version



7/6 2017



7/6 2017



7/6
Anders B. L.

BARRIERS AND OPPORTUNITIES FOR 3D PRINTING IN DANISH SCHOOLS: A QUALITATIVE STUDY

Anders Bod Lund¹, Helga Negendahl², Dorte Hammershøi³, Thomas Ryberg⁴

¹Aalborg University – Engineering Psychology Master's Programme (Denmark)

²Aalborg University – Engineering Psychology Master's Programme (Denmark)

³Aalborg University – Department of Electronic Systems (Denmark)

⁴Aalborg University (Denmark) – Department of Communication and Psychology (Denmark)

Abstract

The advent of affordable 3D printing has provided the possibility for its use in educational settings. Previous studies have demonstrated the benefits and possibilities of these technologies in education [1] [2] [3], and to understand which factors that affect the use of 3D printers in education, an exploratory pilot study was performed, and followed up with a more confirmatory field study. 3D printers were introduced in four different schools in Denmark, and the opportunities and barriers related to the technology were investigated in the pilot study. The participating teachers had responsibility for integrating the technology into their classrooms, and could use them as they found best. Data from the pilot study was gathered from three sources: Semi structured interviews with the participating teachers; open ended questionnaires collected from 67 participating pupils; and field observations of the participating classes. All sources of data were analysed using Robert Yin's five-fold method [4]. Although the teachers did have successful instances of teaching with the 3D printers, the researchers found that improvements could be made. Some practical issues were found, such as little printing capacity which resulted in decreased motivation, due to the long waiting time between finishing a design and printing it out. The teachers struggled to plan learning activities that could provide rich and challenging design processes. To better structure a learning activity, a new approach was introduced and tested in the field study, where the printing capacity was also increased. This approach included having the pupils design objects that could be assessed quantitatively on two parameters, either by calculations or experimentation, and afterwards plotting the results on a coordinate system. By testing this approach in an authentic teaching situation indications were found that this approach would support the desired rich and challenging design process, but that it could also support learning of many 21st century skills among other learning opportunities.

Keywords: Digital Fabrication, Maker Education, Teaching Aids, 3D printing, 21st century skills, Tinkering

1 INTRODUCTION

Maker culture in the form of Fablabs, maker fairs, and maker spaces delivers promises of integrating the ideas of progressive education and inquiry based learning with powerful and revolutionary technologies [5]. This unique combination provides children with the possibility to explore STEM fields in a personal and meaningful way [1] [5] [6]. STEM competencies are desirable for a wide range of industries, similarly maker education can also provide an opportunity to develop 21st century skills. The formulation of these skills is an attempt to define which skills will be necessary in a world where many "traditional" jobs are disappearing, in what is sometimes referred to as the fourth industrial revolution. Maker education places a strong emphasis on many of these skills, through its roots in the pedagogical traditions that also highlight these skills. Further, it adds the technological dimension [5] [6].

However, a question remains on how to actually implement the necessary changes, that will facilitate the teaching of meaningful STEM subjects and 21st century skills, or how to get teachers, who were taught 20th century skills, to teach those of the 21st century. The role of the educator in maker education is different from that of traditional classroom teaching, and how maker education relates to existing curricula [5] remains to be addressed. One of the most profound differences is how mistakes or errors are perceived. In traditional recall based education, error is seen as an indication that the pupil is not learning; however, in maker education, mistakes are seen as essential leverage for learning, as the very situation where a child has the possibility to improve and iterate upon a product and facilitate a process otherwise impossible to achieve. This shift places the teacher in the role of coach, or co-creator, rather than a provider of existing knowledge that should be remembered by the child as accurately as possible. According to Vossoughi [5] maker education often makes use of hybrid pedagogies in which pupils, in

some stages, are working independently and exploratory, and, in other stages, demonstrations, facilitated workshops, and critique are used. Literature also describes several pitfalls and threats to successful maker education; one example being the “key chain syndrome” described by Blikstein [1], or the danger of focusing too much on the tools involved or focusing narrowly on STEM fields [5] [6]. The keychain syndrome refers to a tendency that children will find a somewhat trivial object so fun and exciting to construct, that they will not pursue more complex and challenging tasks. This effect is often observed when creating keychains, since this object can provide too big reward for too little effort, since the object is simple to create, but offers a professional looking personal object. This illustrates that some educators and researchers at times struggle to push maker education beyond certain narrow focusses and deliver the promises of maker education fully.

Different approaches have been proposed on how to create successful instances of learning within maker education. Two books in the *Invent to Learn* series by Sylvia Martinez and Gary Stager [6], and David Thornburg, Norma Thornburg and Sara Armstrong [7], provide an attempt at a comprehensive guide for implementing maker technologies successfully in schools, including information about the different technologies and guides to creating meaningful projects. Vossoughi et al [8] builds the case that even though maker education promotes equity and democratization of technologies, the movement has yet to demonstrate its true potential for equity among genders and ethnicities. One of the ways they propose to achieve these goals is by using certain types of language and social interactions, which their study indicates, can empower children and provide them with self-confidence and pride in their work [8]. Smith et al [2] adds that introducing the concept of design thinking can provide children with “a general understanding of the creative and complex process through which artifacts and futures emerge in processes of digital fabrication.”. Thus, different approaches are currently available for educators who wish to embark on the journey towards introducing maker education in their schools. However, the range of different approaches are still somewhat sparse compared to other pedagogical traditions due to the novelty of the field. The purpose of the present contribution is to propose more tools and expand the range of possibilities for educators wishing to engage in maker education.

2 PILOT STUDY

The study was initiated in the fall of 2016 with a collaboration between the Danish company Create it REAL and the Municipality of Aalborg, a municipality with a population of 210.316 located in Northern Denmark. Create it REAL is a research and development company for 3D printing that specializes in enhancing speed and precision of 3D printers through the use of an advanced control system. This means that the maker technologies included in this study are limited to 3D printers, and, more specifically, to a model named Ideawerk Speed, a 3D printer Create it REAL developed for the Chinese education market with the company Weistek. Together, Create it REAL and the Municipality of Aalborg launched a pilot project to investigate how 3D printers could be introduced in education, and what value it could add to local education institutions. Therefore, an opportunity was given to six schools in which the Municipality of Aalborg and Create it REAL provided financial and technical support. The teachers included in the project taught 6th, 7th and 8th grade, so the study is based on teaching activities for an age group of approximately 12-14 year old pupils. In turn, the schools provided feedback and shared their experiences about teaching with the 3D printers. This also provided an opportunity to investigate how 3D printers are introduced to teachers and how teachers introduce the technology to pupils. In this study, observations will be extracted from these experiences, and these will be used to develop a new approach of introducing 3D printers to pupils with the purpose of unleashing the potential of maker education in order to teach 21st century skills.

2.1 Methods

The recruitment procedure consisted of an employee from the Municipality of Aalborg writing an email to all non-private schools under his jurisdiction, offering them the possibility to participate in the project. The schools had to pay a small entrance fee, and the Municipality of Aalborg would then finance the 3D printers and filament. Six schools started out in the project, but two dropped out. Of the four remaining schools, two were considered rural, one suburban, and one urban. Three of the schools received one 3D printer, and one of the schools received two; all of the model Weistek Ideawerk Speed. The schools did not receive any other maker technologies as part of the project, however, some already had experience with LEGO Mindstorms, and the programming language Scratch. The researchers also provided technical support during the project, as well as a limited amount of suggestions on how to use the technology for teaching.

During this time, the exploratory part of the research project began. The underlying research question was: *What are the potentials and barriers for introducing 3D printing in Danish schools?* In this study, a generally qualitative approach was taken, since the subject matter at hand would take place in highly complex and “messy” situations. Furthermore, due to the sampling process, it was not feasible to obtain a valid control group for comparison. Thus, the subject matter was investigated by gathering data from three different sources; semi structured interviews with the four teachers involved; open ended questionnaires handed out to 68 pupils; and 11 pages of field notes from teaching situations. All field studies were conducted by Helga Negendahl and Anders Bod Lund (“the researchers” in the following). One teacher from each school was interviewed; these were the teachers who had almost exclusively used the 3D printers in the project. The interviews were conducted from mid-December to mid-February, meaning that the teachers who were interviewed later were somewhat further ahead in the process than the first. The questionnaires for the pupils were handed out and answered during the 31st of January, as all the pupils involved in the project met and would go through several workshops that day, including the questionnaire. Finally, field observations were primarily conducted during a theme week at a school in which the pupils had to design mobile accessories for 3D printing during an entire week.

The three sources of data were analyzed separately using Yin’s fivefold method [4] adapted to each type of data. After analyzing and interpreting the data separately, a discussion and interpretation of the emerging themes across all sources of data was performed. Three overall themes were found: motivation, resources, and teaching opportunities. These themes will be explained in the next three sections.

2.2 Motivation

In general, it was found, in all three sources of data, that the pupils had varying degrees of motivation. This led some teachers to suggest in the interviews that 3D printing should be an elective class, leaving only the most motivated and skilled pupils. It was found that two factors primarily had an effect on motivation: 1) The pupils would experience a long waiting time between finishing the design and having the actual printed object, and this would decrease their motivation. 2) It was seen during the observational study and reported in the interviews that creating a personal object would usually improve the pupils’ motivation, but that it would also sometimes decrease the learning potential. This is in contrast to much of the existing literature in maker education where the opposite is claimed; that by creating something with personal meaning STEM fields and other topics are learned more easily [1] [2] [3] [5] [6]. However, this might be an example of the “keychain syndrome” described by Blikstein [1], and that the perceived lack of learning stems from the teacher’s inability to move beyond simple projects with a high reward to intellectually challenging problem solving.

2.3 Resources

There was occasionally a long waiting time between finishing a design until the pupils would have the printed products for evaluation. This can be seen, for instance, through replies to the questionnaire in which some pupils explained that they had learned patience through working with the 3D printers. This was mainly because there were between 12 and 25 pupils to a single 3D printer in most cases, and this was far from enough to keep up with the number of designed objects. This lack of capacity meant that most of the teachers would take over the control of the printing process, gathering all the design files at the end of a designing session, and printing them during the week. This meant that the pupils would not receive the printed product until the next 3D printing lesson, and, in general, the pupils would not control the printing process of their design. This method of printing removes the possibility for going through a truly iterative process. Deci and Ryan [9] also describe lack of control as a major factor contributing to lack of motivation, which, in turn, decreases the possibility and effectiveness of learning.

2.4 Teaching opportunities

The teachers in the project also mentioned plenty of opportunities for interesting learning situations. These include the potential for interdisciplinary curricula, including projects that connect 3D printing to other topics or technologies. Our observations also showed some instances of pupils going through an iterative design process to reach a self-determined goal, but it was also seen that many pupils were victims of the keychain syndrome and would simply find a pre-designed mobile cover, write their name on it, print it, and be content with the result. Thus, the opportunities for rich intellectual design processes and exploration of STEM fields were obviously present, but they were not necessarily realized. In this regard, it should also be mentioned that all the teachers in the present study were novices when it came to 3D printing. In addition, very little predefined material was at their disposal, and even less in Danish.

This meant that many teachers prepared their own material for teaching activities using the 3D printer. The teachers mentioned that, with little time to prepare before each class, this could be a challenge, especially when a lot of the time was used to fix printer jams as well as printing the objects from previous classes. Therefore, we sought to find an approach to use the 3D printer that would support exploration of STEM fields, and minimize the keychain syndrome, especially for teachers new to maker education.

3 THE ORESMIAN COORDINATE SYSTEM

Based on the results of the exploratory study, a creative idea generation session was performed by the researchers based on the principles described by Hansen and Byrge [10]. This method includes providing carefully selected stimuli during the idea generation phase in order to escape obvious ideas, and create novel and innovative ideas by forcing the participants to apply their previous knowledge in new contexts. This method proved to be very productive and resulted approximately 50 ideas. Of these, only a few were selected to be further refined and implemented. In the end, only one was implemented in an authentic situation. This was, what we dubbed, the Oresmian Coordinate System (OCS), a rectangular coordinate system named after the French natural philosopher and astronomer Nicole Oresme who utilized a rectangular coordinate system and pre-dates René Descartes, whom the rectangular coordinate system is otherwise named after. This coordinate system would in our proposal be a physical entity made from large pieces of paper.

The idea of the OCS was conceived on the background of the teachers' apparent lack of strong structured ways of utilizing the 3D printers for STEM projects, and it was created to accommodate that need, while still supporting the open-ended questions that maker education endorses. Another source of inspiration for the OCS was a learning activity that was encountered previously to this study; here the pupils would design and 3D print models of highway bridges, stress test them by adding weights until they would break, and calculate the price of materials for building the bridges in real life. Although no data was gathered from the learning activity it is considered successful, achieving the type of intellectually challenging problem solving and an iterative design process that can fulfil the promise of maker education. Furthermore, it seemed that the act of breaking the designed object, seemed to be an effective means of avoiding the keychain syndrome, since created a higher emphasis on reflection and process awareness. The OCS is a somewhat simple, although powerful addition to this, and simply adds a coordinate system with the strength of the bridge along one axis and the cost of the bridge along the other. When a bridge would have been designed, printed, and tested, it would be placed on the OCS, at the coordinate that corresponds to its price and strength. The hope was that the OCS would thereby create a sense of direction in the design process, since the best bridge would be placed as low on the x-axis and as high on the y-axis as possible, creating the perfect compromise of price and strength. It was hoped that the coordinate system would achieve things such as. 1) Providing the pupils with a tinkering mind-set by promoting continuous problem solving, 2) providing the pupils with a visually accessible tool for planning their next iteration, based on lessons learned from the current and previous iteration, 3) providing the teacher with a tool to monitor the pupils' design process, and 4) serve as a method of presenting an overview of the design process to peers. These are closely related to 21st century skills, which other researchers have also highlighted as interesting learning possibilities within maker education. These include, problem solving, knowledge construction, collaboration, which are all skills we hope the coordinate system will train. A more precise definition of these skills can be found below. Even though the OCS was envisioned with the bridge design in mind, it was hoped that it would be a flexible tool that could be used in a broad variety of learning activities

4 FIELD STUDY – TESTING THE ORESMIAN COORDINATE SYSTEM

After conceiving the idea of the OCS, it was decided to test it in an authentic classroom setting, to test if this approach would make it possible to achieve more iterations and problem solving, while avoiding the keychain syndrome. It was therefore decided to conduct a field study in which the system could be tested in one of the schools participating in the project. The school had planned a theme week where one of topics was "technology and gaming development" which around 36 pupils had chosen to participate in during the week. The school was interested in trying out a new learning activity and the researchers then helped to plan this activity. The teacher who had the responsibility for this activity was new to 3D printing. She will be referred to as Rachel in the following.

4.1 Method

During this week, two of the researchers, Anders Bod Lund and Helga Negendahl, would participate to gather data, but also to act as helpers and technical support. This meant that the role of the researchers was as action researchers. However, Rachel had the main responsibility for the learning activity during the week, and the researchers adopted to a higher degree the role of observers compared to the pilot study. The main source of data during the week was field notes and video recordings. The video recordings were unfortunately limited by the fact that not all the parents of the pupils had signed consent forms allowing for video recording. Thus, only the pupils who had signed consent forms were recorded. The video data and field notes were coded mostly for instances of 21st century skills and analyzed with the fivefold method [4]. No official list of official 21st century skills exists; however, a Danish government agency has provided a list of six 21st century skills, based on the ones defined by Microsoft, and these are as follows: Collaboration, real world problem solving and innovation, knowledge construction, competent communication, skilled use of information and communication technology, and self-regulation [11]. To deepen our understanding of the data, a video review session was also planned in which Rachel participated, as well as another teacher who had been responsible with teaching using the 3D printer prior to the theme week, here referred to as Bruce. This provided the opportunity to relate some of the video recordings to the teachers' previous experiences with 3D printing activities.

4.1.1 *Preparing for the theme week*

From the preceding pilot study, the researchers had several ideas of what would support a successful learning activity during the week. Therefore, several actions were taken. First, the printing capacity was increased significantly, and the aim was that groups of about three pupils should share one 3D printer. Therefore, extra 3D printers were provided by Create it REAL for the week. This was to make it possible for each group to plan their own time and printing process, providing a deeper understanding of the actual manufacturing process. In the exploratory study, the teachers had requested activity plans, and the researchers therefore provided a guide that would help the teacher facilitate the workshop with designing, testing, and evaluating their designs using the OCS. The guide also included 1) a general introduction to 3D printing and its impact on society, 2) guides for the use of CAD software, 3) a description of an iterative design process, 4) a guide to Create it REAL's printers, and 5) a problem statement for the workshop.

4.1.2 *Structure of the week*

During the theme week, the 7th, 8th and 9th graders who chose the "technology and game making" activity would participate in this workshop. During the first three days (Monday, Tuesday, and Wednesday), the pupils would rotate between three different workshops, trying a new one each day. The other workshops were eSports and LEGO Mindstorms. This meant that the researchers had a unique possibility to test out a predefined learning activity using the OCS each of these days, and adjust the learning activity as needed. During the last two days of the week (Thursday and Friday), the pupils could choose between the three different activities that they had tried during the week. During these two days, only eight pupils chose 3D printing. These eight pupils worked on three different projects, each with very different foci and with different design processes and motivations. Therefore, the data extrapolated from the final two days will be treated more as a type of case study, due to the small group of pupils and the intensity of the data from these.

4.1.3 *Sampling*

From the researchers' point of view, the sampling can be seen as an opportunity sampling, since the school provided and planned the theme week initially without help from the researchers, but later invited the researchers to help plan the activity. Therefore, the researchers seized the opportunity and got a group of pupils to test out the idea, in order to extract data. During the first three days, between 11 and 13 pupils worked with 3D printing each day, and, in total, 37 pupils worked with 3D printing. This was considered a somewhat large sample, due to the general circumstances, and, therefore, general aspects of the activities in these days can be found through qualitative analysis. The sample has some inherent biasing issues, as the pupils could choose themselves what they wanted to do during the theme week, with only one of the themes being technology focused. Therefore, the sample of pupils are believed to be somewhat biased, as the pupils will most likely be the ones most interested in technology in the first place. Perhaps, because of this, a gender bias can also be seen, as only four girls and 33 boys participated.

4.2 Findings

In the following, the findings from the field study and the video review session of it will be presented. The data from both these sessions were analyzed by coding it, with a special emphasis on the 21st century skills that were identifiable during the coding. The analysis was focused on the instances, where the OCS or testing were present, since this study was focused mainly on investigating the effects of these. The findings will be parted into three segments: bridges, boats, and spinning tops. These reflect three different projects that the pupils engaged in during the week. All the 37 pupils engaged in the bridge project during the first three days. The spinning tops was a project envisioned by a pupil, hereafter referred to as Fred. Fred worked alone on the project during Thursday, but Friday he was joined by another pupil, hereafter referred to as Mick. Fred found a design for a gear driven spinning top online and decided to try to improve this design. The parts were printed, and the spinning top was plotted on the OCS with weight and average spinning time. Fred and Mick worked together and, in the end, they created a tournament in which the different versions battled each other. In addition to the spinning tops, another group created boats. In this group, two pupils participated Thursday, and four participated Friday, however, only one pupil participated both days, meaning that five pupils participated in total. The boat group designed and printed boats. The boats were also plotted on the OCS, with the weight of the boat and the weight of the maximum load as the axes. The boats were tested in a small bowl where they were placed in water, and afterwards weights were placed in them. Finally, another group chose to make fidget toys, however, they were not included in the analysis for various reasons. First, they did not have signed consent forms, and, therefore, no video data was obtained. Second, they did not apply the OCS in their process.

4.2.1 Bridges

The bridges were tested by placing weight on top of them in the form of paper stacks. Afterwards, they would be plotted on the OCS, and then Rachel would have prolonged conversations with the pupils regarding their design, ideas, issues, and plans. Rachel would guide the pupils, but not directly take charge of the process. The testing of the bridges was seen as a quite motivating factor, and this was verified by the teachers during the review session.



Figure 1. A picture of two testing scenarios. On the left a testing of a bridge is performed, with multiple pupils working together. On the right a boat can be seen with an uneven weight distribution.

One of the “foci of analysis” described in interaction analysis is the effect that spatial organization of the world has on one’s interaction [12]. In this study, we saw an effect on the way the classroom was structured spatially on the type of interactions that took place. All groups in the bridge project would have their own table where almost all the designing and CAD modelling was done. The 3D printers were also at this table, and, therefore, the stages of designing and printing were performed at the group’s own table. This meant that interaction was mostly limited to be between the pupils in each group. However, when testing began, this would be performed in the middle of the classroom. This led to a much higher degree of collaboration between the groups. The stack of paper that was placed on top of the bridge would be in the range of 1,5 meters, and, as such, the stack had to be supported by the pupils. Finally, the weight of the paper was, more often than not, not enough to actually break the bridges, and, by their own initiative, the pupils would sit on top of the paper stack. To ensure a somewhat continuous way of adding weight, the lightest pupils would sit on the stack first, and as the test went on the heavier pupils would sit on top of it. Because of this, the testing became an activity requiring the participation of most of the class, and almost everyone followed the process carefully. Finally, the OCS

was placed on the teacher's desk. After the testing was performed, and the price of materials was calculated, the teacher asked pupils to come up to the coordinate system to place the bridge along with a post-it note stating the strength and price of the bridge. Here, some interaction between the groups happened, although not to the same extent as in the testing situation. After the placement of the bridge and the post-it was completed, the groups would return to their own desks and design a new version. The fact that different areas of the classroom were tied carefully to the different phases of the development also meant that it was easy for the teachers and researchers to identify which phase the pupils would be in at different times.

4.2.2 Boats

The group who made boats investigated how much weight a boat could load before sinking. In the coordinate system, they plotted the weight of the boat along one axis, and the weight of the load along the other, trying to create a light design that could hold a heavy load. Here, the testing situation was seen as being somewhat less fun and exciting compared to the other testing situations, but the teachers in the review session believed that it was also rich in learning possibilities. This was also one of the videos that was viewed, where Rachel spoke a lot with the pupils, but mostly in a guiding and inquiring way. Rachel verified this in the review session, and explained that it was her intention. When asked what role they thought she had in the clip, the teachers replied as follows:

Bruce: *"I think she has a counselling role, to help guide him and get things thought through."*

Rachel: *"Well that was the intention, that he was the one that should do the thinking and come up with ideas of what to do next."*

The testing required quite a lot of tweaking in order to create a valid test design. For instance, two different strategies were used when adding the weights to the boats. Sometimes they were added one at a time while the boat was in the water, and other times the weights would be added out of the water, and the boats would be placed in the water with the weights already in. Generally, it was discovered that the boats had issues with balancing, if the pupils had not been careful in making the boats symmetrical, and, thus, much of the test consisted of the pupils carefully placing the weights on the boat in a way that would ensure balance. It was also discovered that some boats would sink straight down when enough weight was placed on them, whereas others would tilt to the side.

4.2.3 Spinning Tops

The researchers and the group came up with a testing situation together in which the spinning top would be started three times, and, using a stopwatch on a phone, an average spin time would be calculated based on the three measurements. Hereafter, it was suggested that the group used the OCS with weight along the horizontal axis, and average spinning time along the other. The first version that was printed, was a design from a website that was not modified, whereas in all later versions the tip or the body of the spinning top were modified in different ways. The second version that was printed was slightly heavier and had a slightly longer spinning time. The group would then place the post-it's on the OCS, and when a researcher asked how they would use this information to create version 3, Fred answered: "I am thinking more weight, even more weight, because clearly the more weight, the faster it spins. So, the more weight, the better." This clip was shown in the review session, and here Bruce, who teaches these pupils math and science, said that he believed that the coordinate system was one of the things that helped Fred understand the relationship between weight and spin time, and that he might not have reached this conclusion without it. Bruce also mentioned that the concept of a coordinate set is something that Fred would normally have a hard time learning, but that when this concept was turned into something tangible as the relationship between weight and spinning time, he did learn it quite well. Friday, when Mick joined Fred, they worked independently and managed their own time, planning iterations ahead as well as testing the different versions without any help from the teacher. The third version was designed to be much heavier than the previous two and had an average spinning time almost twice as long as the previous versions. Thus, their hypothesis was verified through the designing and testing of the spinning tops. In the fourth version, the group decided to add spikes on the side because they had also planned a tournament, and they believed that the spikes would help the spinning tops in a battle situation. However, even though this was the heaviest out of all four, it also had the worst average spinning time of all the spinning tops by far, thus this spinning top did not follow the previous pattern. As mentioned, the spinning tops were tested in two different ways, firstly they were tested for their average spinning time, and afterwards they were engaged in a battling tournament in which the spinning tops were pitched against each other. This was done by starting two spinning tops at the same time, in a dish where they would hit each other, and the last one standing would win the match.

The researcher had suggested that the group should use a tournament style competition, pitching version one against version two, and version three against version four, and let the winners of these meet each other in a final. However, the group decided to use a structure similar to the group stage of a tournament instead, because they wanted all the spinning tops to meet each other, because they believed that it would yield results that were more interesting.

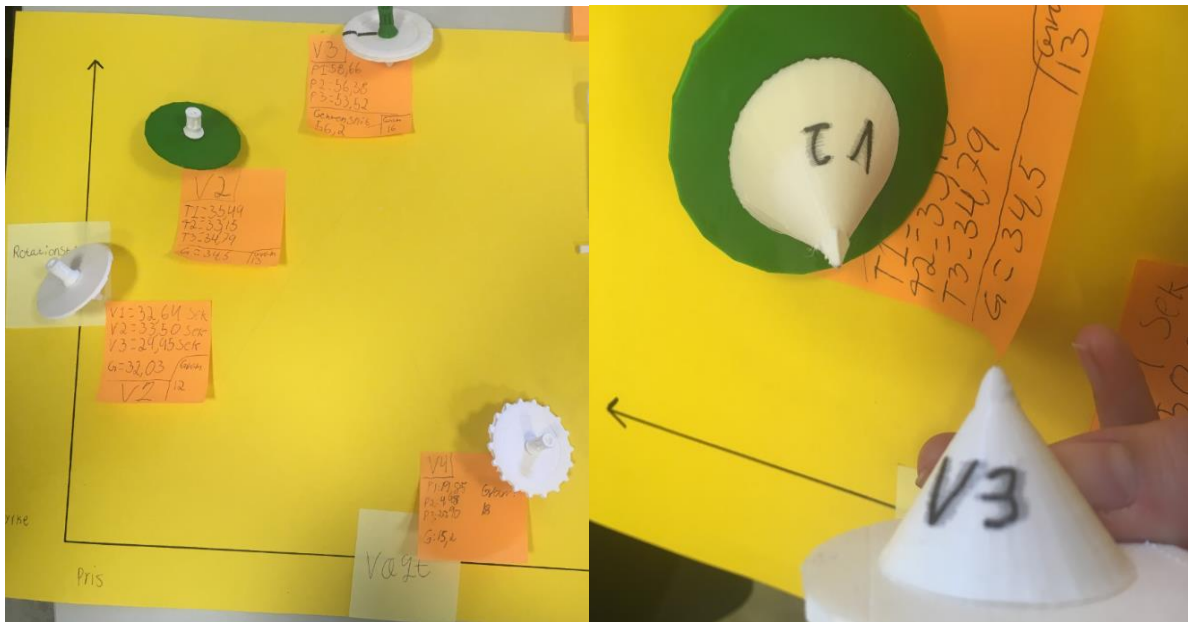

Figure 2. Left: a picture of the Oresmian Coordinate System as it was used to design spinning tops. From left the 1st, 2nd, 3rd and 4th version can be seen. Through the first three iterations of the spinning tops, the average spinning time increased along with the weight, but, when spikes were added in the fourth version, the spinning time dropped vastly.

4.2.4 21st Century skills

It was found that the OCS could support both knowledge construction and problem solving, when the axes were chosen according to the relevant learning objective. For the bridge and boat projects, the coordinate system was helpful in evaluating each design against each other and finding issues and ideas for improvement of the product, thus, also supporting a tinkering mind-set [6]. However, when creating the spinning top, it seemed that the nature of the OCS changed. Instead of it being merely a way of locating errors, it became a way for the group to build a theory about which factors would improve the spinning tops. When the first two models were printed, a hypothesis was formed regarding how increased weight would increase the spinning time of the spinning top, and this was tested by creating another even heavier spinning top that followed the same pattern. The pupils engaged in this activity seemed to not only construct knowledge, but also engage in what Martinez and Stager describes as engineering: “**Engineering** extracts principles from direct experience. It builds a bridge between intuition and the formal aspects of science by being able to better explain, and predict the world around us” [6]. Thus, it was seen that the OCS, in this case, supported the 21st century skills of problem solving and knowledge construction, but can also help the pupils move from stages of making to stages of tinkering, and even engineering [6] [11].

During the testing, it was also seen that pupils actually engaged in problem solving, especially when testing the boats. The problem solving, here, seemed to happen at two levels. One level was solving problems with the test itself, where the pupils would tweak the method to achieve valid results. Another level was using the test as a basis for solving problems and issues with their design. The testing was also a phase where a high level of collaboration was seen. With the bridges, it was a necessity to collaborate between the groups, otherwise the testing could not be completed.

Another 21st century skill that was supported during the learning activity was self-regulation. During the initial couple of iterations, the teacher employed a degree of external regulation, telling the pupils what they should do and when to do it. However, as the day progressed forward, and the pupils got familiar

with the technology and the design phases, they could plan and manage their own time. Whenever the pupils had started a print, and they had calculated the price of the bridge, they were allowed to have a break until the print was finished, and the test could start. The pupils generally managed this responsibility well. During the last two days, an even higher level of self-regulation was seen, and the pupils would not only plan their own time, but also set their own goals and work structured towards fulfilling them. This is exemplified by the group that created spinning tops, who, without much ado, planned an alternative tournament structure than the one the researcher had suggested, because they wanted all the spinning tops to meet each other. During these days, some pupils even found the lunch break highly inconvenient, as this meant the classroom had to be locked, meaning that they could not work on their designs.

Thus, we saw a very high level of four of the six 21st century skills: Problem solving, collaboration, self-regulation, and knowledge construction. The final two 21st century skills as described by Microsoft is communication and skilled use of ICT tools [11]. These two skills were not employed to a great extent during the week, however it is believed that this is rather due to the learning activity, and that the OCS can in fact support these 21st century skills if desired.

5 CONCLUSION

The general findings from this study all rely on qualitative action research and analysis of data from these situations. This was done mainly because of the sample used in the study, but also because the type of learning that was investigated does not necessarily measure well on predefined quantitative scales, which might be the reason why qualitative methods are most often used in research regarding maker education [5]. The initial pilot study yielded a diverse and rich source of data from which we were able to identify several barriers, but also a great deal of possibilities for the 3D printing technology in the classroom. This deep and rich understanding was used along with creative idea generation methods to envision the OCS [10]. This method helped tie the understanding achieved through the exploratory study to the researchers' backgrounds in engineering and design, both of which contributed to this idea, which is a core aspect of the method developed by Hansen and Byrge [10]. The testing situation of the OCS was unique, since it provided an opportunity to repeat the bridge activity three times in a row, but also to use the OCS for a more free and pupil driven activity during the last two days. In general, the findings from the field study showed that the OCS would support teaching of a wide variety of 21st century skills, help avoid the keychain syndrome, and provide rich possibilities for learning.

5.1 The future of the Oresmian Coordinate system

The testing of the OCS was done in collaboration with a math teacher who was highly motivated for using it, and even stated herself in the review session that she loved the idea. This, along with the fact that the sample of pupils in this study might have been especially technology interested, does provide a certain bias. The school that the system was tested in was a school that had a special focus on sports, and included a program for talented young athletes. This is probably one of the reasons that the competitive element of the bridge project worked so well, and it should be considered whether this competitive element would work for other schools as well. These aspects produce a sampling with a variety of biases, and therefore further testing is required to understand what the OCS can add to maker education.

Testing of different age groups would provide an interesting insight into how younger pupils will be able to understand the concept of a coordinate system, and what it can add to design processes. However, it could also be interesting to test the system for older pupils who might be able to apply even more knowledge about science and math. Furthermore, the very low participation rate of girls in the field study, only 4 girls and 33 boys, means that the findings in this study is based mainly on data gathered from males [5]. Furthermore, we propose that the OCS can be used for a variety of other maker technologies, as well as in hybrid activities where more than one maker technology is used. The OCS could even be applicable to activities like chemistry or biology, activities that are not necessarily seen as a part of maker education. We also believe that the system could be applied to a real world problem, which would entail more significance for the pupils, and this also means that the 21st century skill of problem solving as described by Microsoft would be even more profound [3] [11] [8]. The results of this study indicates that the OCS can be a strong tool for inquiry-based learning and fits well within the pedagogical roots of maker education.

ACKNOWLEDGEMENTS-

We would like to thank Jeremie Pierre Gay and Thomas Overgaard for proposing this project. We would also like to thank the whole Create it REAL team for always working hard to improve their technology and providing swift solutions for technical issues. Furthermore, we would like to thank Ian Rubeck Stenz from Friskolen Skallerup for envisioning the idea of designing, printing, and testing bridges - an idea that was built heavily upon in this study. Finally, we would like to thank all the teachers who have been a part of the project: Robin Lyksholm, Alex Daniel Olesen, Hans Peter Bang Jensen, Lars Berg Kristiansen, Gitte Buus Pedersen, Søren Hausgaard Andersen, and Randi Sørensen – thank you for going above and beyond in your quest to adopt interesting technologies in your classrooms amidst your busy schedules. At last, we would like to thank Rikke Bod Lund for help with grammar and proof reading.

6 REFERENCES

- [1] P. Blikstein, "Digital fabrication and 'making' in education: The democratization of invention," *FabLabs: Of machines, makers and inventors*, pp. 76-79, 2013.
- [2] R. C. Smith, O. S. Iversen and M. Hjorth, "Design thinking for digital fabrication in education," *International Journal for Child-Computer Interaction*, pp. 20-28, 7 November 2015.
- [3] V. Kostakis, V. Niaros and C. Giotitsas, "Open source 3D printing as a means of learning: An educational experiment in two high schools in Greece," *Telematics and Informatics*, pp. 118-128, Maj 2015.
- [4] R. Yin, *Qualitative Research, from start to finish*, Guilford Publications, 2011.
- [5] S. Vossoughi, "Making and Tinkering: A Review of the Literature," ResearchGate, 2014.
- [6] S. L. Martinez and G. Stager, *Invent to learn: Making, Tinkering, and Engineering in the Classroom*, Torrance, California: Constructing Modern Knowledge Press, 2013.
- [7] D. Thornburg, N. Thornburg, S. Armstrong og G. S. Stager, *The invent to learn guide to 3D printing in the classroom, recipes for success*, Constructing Modern Knowledge Press, 2014.
- [8] S. Vossoughi, M. Escudé, F. Kong and P. Hooper, "Tinkering, Learning & Equity in the After-School Setting," in *Fablearn*, Stanford, 2013.
- [9] R. M. Ryan and E. L. Deci, "Self-Determination Theory and the Facilitation of Intrinsic Motivation, Social Development, and Well-Being," *American Psychologist*, vol. 55, no. 1, pp. 68-78, 2000.
- [10] S. Hansen and C. Byrge, *Kreativitet som uhemmet anvendelse af viden*, Frydenlund Academic, 2013.
- [11] Microsoft Partners in Learning, "21CLD Learning Activity Rubrics," January 2017. [Online]. Available: <https://education.microsoft.com/GetTrained/ITL-Research>. [Accessed Maj 2017].
- [12] B. Jordan and A. Henderson, "Interaction Analysis: Foundations and Practice," *The Journal of the Learning Sciences*, vol. 4, no. 1, pp. 39-103, 4 February 1995.

Appendix B

Learning Activity Guides

In the following, the learning activity guides will be presented. The first 15 pages are the guide Rachel received to plan the learning activity about bridges, this guide is in Danish. Hereafter 19 pages with a new learning activity guide is included, this guide is in English and based on all the findings in this study and our previous experiences (see E). The purpose is to give teachers a guide to plan a successful learning activity with the OCS.

Design en motorvejsbro

Varighed: 1 dag (6-8 lektioner)

Niveau: intro

Fælles mål: Naturfaglige mål, 21 skills samt Matematik faglige mål

Kapacitet: Minimum én 3D printer pr. 6 elev

Materiale: Gennemgang af forløb med video og tekst på dansk

Beskrivelse

Denne opgave er bygget om en case hvor flere af de danske motorvejsbroer skal skiftes ud. Eleverne skal arbejde i grupper som entreprenører og give deres bud på et design af en motorvejsbro. Derefter 3D printer grupperne deres design og eleverne skal via dialog og test evaluere og forbedre deres design over flere omgange. Til sidst vil eleverne fremlægge deres design og læreren eller en gæst kan eventuelt vælge den løsning de finder bedst. Fordi dette er et introduktionsforløb foreslår vi at du går igennem følgende trin for at sikre at dine elever har kendskab til teknologien og arbejdsmetoderne:

Hvad er en 3D printer (side 2)

Hvordan laver man projektarbejde med en 3D printer (side 4)

Hvordan designer man 3D modeller (side 5)

Introduktion til motorvejsbro case (side 7)

Gruppearbejde (side 10)

Afsluttende fremlæggelse (side 12)

På de følgende sider vil du finde alt hvad du skal bruge for at tilrettelægge undervisningen, inklusiv en opgavebeskrivelse du kan give til dine elever (side 8-9) . Her er links til videoer og introduktioner som du kan vise dine elever eller bruge til selv at få en forståelse for materialet og en forklaring af hvordan du opnår de Fælles Mål. **Husk at du altid kan ændre på forløbet for at få det til at passe til din undervisning og dine elever.**

Fælles mål

Gennem forløbet vil eleverne lære at bruge forskellige kompetencer som er en del af de Fælles mål. På side 13 er der komplet liste hvordan de Fælles mål bliver opnået igennem forløbet. Men du kan forvente at eleverne når de naturfaglige mål:

Undersøgelse

Modellering

Perspektivering

Kommunikation

Du kan også forvente at de forbedre sig i disse 21st century skills:

Kollaboration

Problemløsning og innovation

Videnskonstruktion

Kompetent kommunikation

Selvevaluering

It og læring

Hvis du i talesætter matematikken kan du også forvente at eleverne arbejder med disse kompetencer:

Matematiske kompetencer

Tal og Algebra

Geometri og måling

Hvad er en 3D printer

Start ud med at give en introduktion til hvad 3D printning er og hvilke muligheder teknologien giver i den virkelige verden. Vi har samlet nogle eksempler og videoer som du kan bruge til din undervisning til at give eleverne en forståelse for hvilket potentiale teknologien har.

At bygge med lag

3D printning kan henvise til mange forskellige maskiner, der printer med et væld af materialer, men fælles for dem alle er at de bygger et objekt i mange små lag. Det betyder at de objekter der bliver printet bliver konverteret fra en 3D model, til en masse 2D skiver i en proces man kalder "slicing". 3D printning er en additiv fabrikationsteknologi, i modsætning til subtraktive fabrikationsteknologier som laserskæring og CNC fræsning. I de subtraktive metoder vil man starte med et stykke materiale, en plade ved laserskæring eller en blok ved CNC fræsning, og derefter fjerne det materiale, indtil man når det ønskede resultat. Ved 3D printning vil man derimod tilføje materiale, og derved starte fra ingenting, og tilføje materiale præcis der hvor det skal bruges. Derfor er 3D printning på nogle punkter også mere økonomisk og ressourcevenligt siden det placerer materialet der hvor det skal bruges, fremfor at fjerne materiale der hvor det ikke skal bruges.

At printe bygninger

En 3D printer kan faktisk bruges til at printe bygninger ud med. Herunder ses et billede af en beton 3D printer fra et firma i USA. Ideen startede da en far ville bygge et slot til sin datter, og med sin viden indenfor mekanik og maskiner kunne han selv bygge en 3D printer der kunne klare opgaven for ham. Her er et nyhedsindslag om det på engelsk: <https://www.youtube.com/watch?v=DQ5Elbvvr1M&t=231s>



At printe proteser

3D printning er rigtig godt i de tilfælde hvor objekter skal tilpasses specielt til en enkelt person. Denne problemstilling findes især ved proteser. En protese er et kunstigt objekt der kan erstatte en manglende kropsdel. Et af de helt store udfordringer ved at lave proteser til børn, er at en protese er forholdsvis dyr, og fordi børn vokser hurtigt vil mange proteser kun være brugbare i enkelte år, eller endda kun få måneder. Men ved hjælp af en 3D printer, kan man printe proteser der er forholdsvis billige at lave, og hvis dele af dem går i stykker eller barnet vokser kan man simpelthen bare printe nye dele. Fordelen er også at man kan printe proteser der er inspireret af superhelte og andre ting, hvilket gør at man kan lave proteser der rent faktisk har et legende element. Her er et videoklip om at 3D printe håndproteser:



<https://www.youtube.com/watch?v=3ZyDLGgSj60>

At printe organer

En af de nyeste skud på stammen indenfor 3D printning, er muligheden for at lave realistiske og funktionelle organer. Man bruger allerede 3D printede modeller til at øve komplicerede medicinske indgreb. Eksempelvis brugte to amerikanske læger 3D printere modeller til at øve en seperering af siamesiske tvillinger der sad sammen i hjertet: <http://nyheder.tv2.dk/udland/2016-09-04-siamesiske-tvillinger-hang-sammen-ved-hjertet-skilt-ad-takket-vaere-3d-printer>. Man undersøger dog også muligheden for at 3D printe rigtige fungerende organer og kropsdele da dette i teorien kunne eliminere behovet for organdonationer.

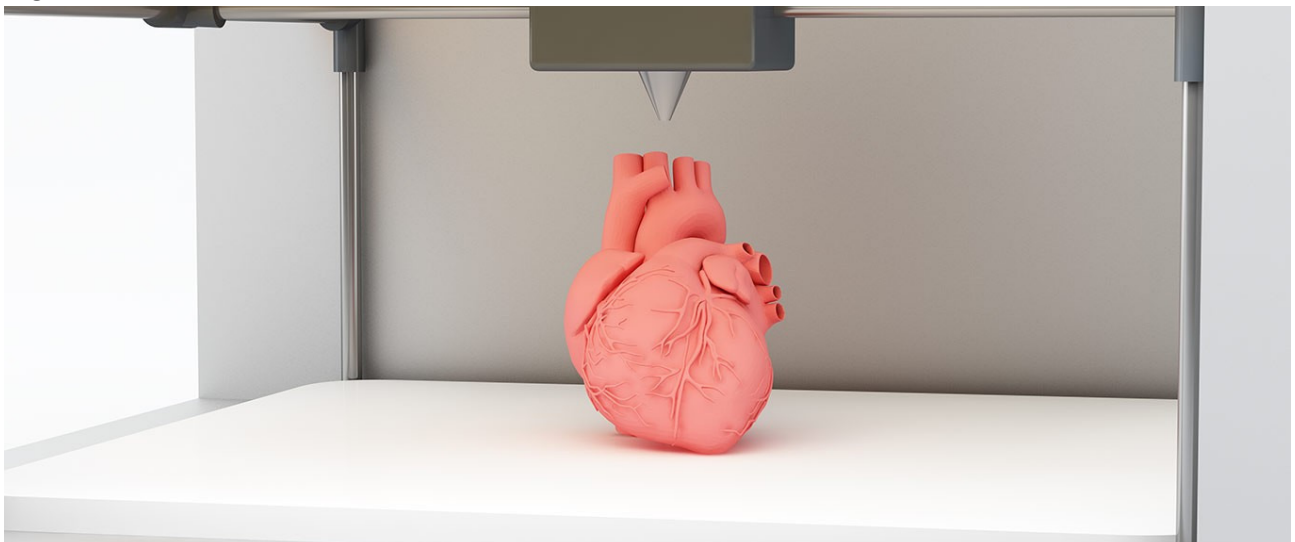

Projektarbejder med en 3D printer

Projektarbejdet med en 3D printer giver eleverne mulighed for at evaluere og re-designe deres objekter over flere omgange. Når eleverne går igennem processen flere gange vil det styrke deres evner indenfor problemløsning og innovation samt de naturfaglige Fælles mål: Undersøgelse, Modellering, perspektivering, kommunikation. Det er vigtigt at eleverne forstår at denne arbejdsproces fra starten af således at de er opmærksomme på hvad hvert enkelt trin tilføjer til deres arbejde.

Det er vigtigt at forberede eleverne på at når man arbejder på den her måde er man ikke færdig med opgaven når ens første produkt er blevet 3D printet ud!

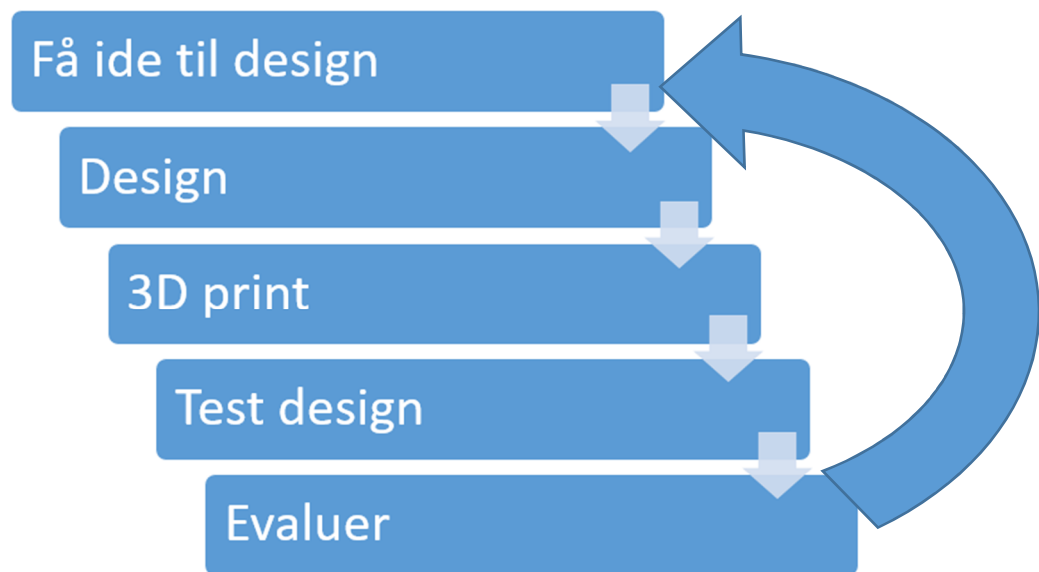

Når man arbejder på denne måde bliver man aldrig færdig, det er altid muligt at forbedre ens produkt, du kan sammenligne det med når virksomheder laver en ny udgave af et det samme produkt eksempelvis en iPhone som alle eleverne kender. På billede er der et eksempel hvor eleverne har designet iPhone covers, her er det tydeligt at der sket en ændring i designet løbende.

Eleverne kan altid gøre deres design billigere, mere holdbart, smartere eller pænere.



Hvordan designer man 3D modeller

Når eleverne skal designe en model som skal 3D printes skal de bruge et designværktøj, ligesom de bruger et skriveprogram når de arbejder på en skriftlig opgave. Du kan med fordel give dine elever en introduktion til designværktøjet, men det er som minimum vigtigt at du ved hvordan det fungerer. Efter modellen er færdig skal den over i REAL vision hvor modellen gøres klar til 3D printning. Du finder her en guide til designværktøjet Tinkercad som vi anbefaler at du bruger da det både er gratis og brugervenligt.

Introduktion til Tinkercad

Tinkercad er et designværktøj der er særligt nyttigt til at designe filer der kan 3D printes. Tinkercad er et browserbaseret program, hvor man kan designe tredimensionelle figurer, ved at sammensætte forskellige geometriske former. Du finder programmet her <https://www.tinkercad.com/>. Til at komme godt igang har vi fundet en udmærket tutorial, selvom interfacet er blevet opdateret lidt siden: https://www.youtube.com/watch?v=KCaenAGeK_Q&t=35s.

Vi foreslår at du som minimum for introduceret eleverne til følgende:

- Hvordan figurer tilføjes og flyttes i workplanet, herunder at flytte dem op og ned i planet
- Hvordan man ændre kameravinkel og zoomer ind og ud
- Hvordan man manipulerer figurer, herunder størrelse og rotation
- Hvordan man laver huller i figurer, og hvordan man laver en figur til et hul
- Hvordan man grupper og un-grupper figurer
- Hvordan man får figurerer til at stå på en lige linje, ved hjælp af align funktionen.

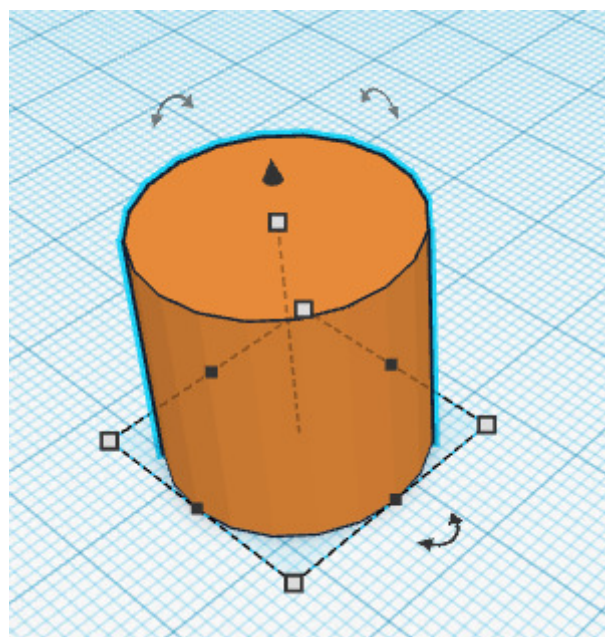

Gode råd om Thinkercad

Der er nogle faldgruber som eleverne kan falde i. Du kan vælge at lade eleverne selv gøre sig de erfaringer da det kan være en del af lærings processen, men kan også forsøge at komme dem til livs før de opstår.

Kameravinklen: Nogle elever glemmer at ændre kameravinklen når de designer. Det kan resultere i at deres figur ikke altid sidder rigtigt sammen, se billedet hvor det viser sig at taget ikke sidder fast når kameravinklen ændres. I 3D design skal man huske altid at ændre kameravinklen, og betragte sin figur fra flere vinkler.

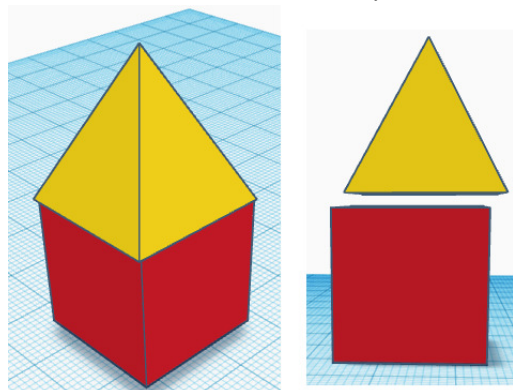

Rotation: Når eleverne roterer en figur kan de let komme til at stille det en lille smule skævt, et skævt design kan gøre det svært at 3D printe og kan i værste flad medføre at eleven må starte helt forfra. Et skævt objekt opstår eksempelvis hvis eleven i stedet for at rotere figuren 45° roterer den 43° grader. Når figuren slippes "nulstilles" den, og det kan derfor være rigtig svært at rette op på skæve designs. Når der roteres kan man med fordel rotere figuren i den "inderste" ring, hvor at figuren drejes 22.5° af gangen, hvor det i den "yderste" ring er muligt at dreje figuren enkelte grader.

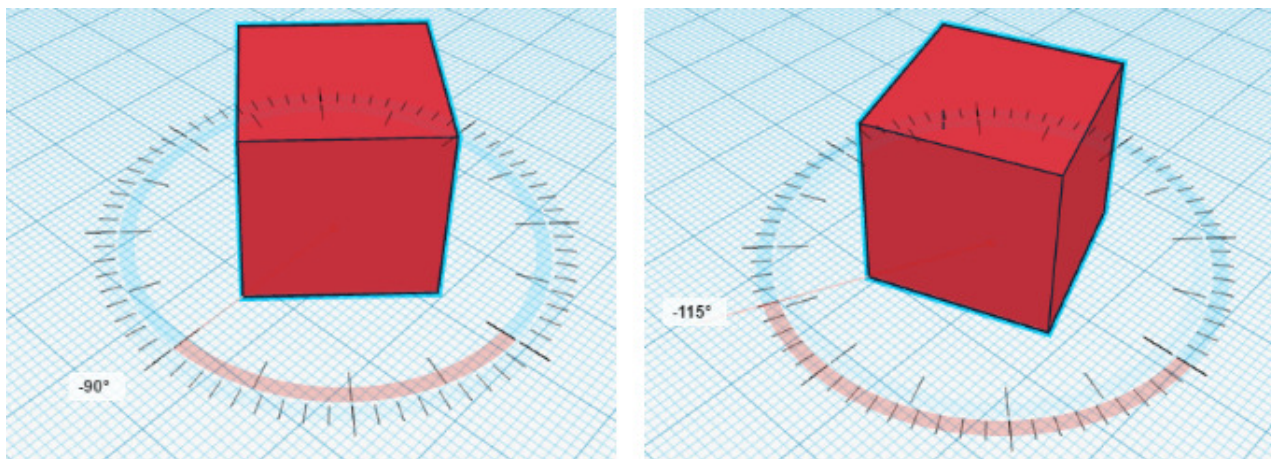

Introduktion til REAL vision

Dette program bruges til at gøre modellerne klar til print. Du åbner STL. Filen som er designet i Tinkercad, hvor efter REAL vision. Vi anbefaler dig at du har prøvet at 3D printe en model før du viser det til eleverne, derfor er der vedlagt nogle STL. Filer som skal bruges til undervisningen du kan teste.

Gode Råd

Oplær eleverne i Real Vision: Vi anbefaler dig at du lader eleverne stå for så meget af 3D printningsprocessen selv. Dette giver eleverne en bedre forståelse for hvordan 3D printer processen fungerer, men det frigør også dig for en del arbejde. Vores vurdering er at mange af eleverne fra 6 klasse og op selv vil kunne benytte sig af REAL vision og starte 3D printeren.

Guide til REAL vision

REAL vision er det program der konverterer STL filer til F-kode. Når ens model er downloadet fra eksempelvis tinkercad, vil den ofte være i STL format. REAL vision konverterer derefter ens 3D model til en række af 2D skiver som 3D printeren kan følge, også kaldet F-kode. REAL vision har en masse indbyggede funktioner, som kan bruges når man skal gøre et produkt klar til print. Vha. af knapperne der er vist herunder kan man, skalere en model, rotere en model, duplikere en model, flytte en model rundt på printer platformen, spejle en model, og meget andet.

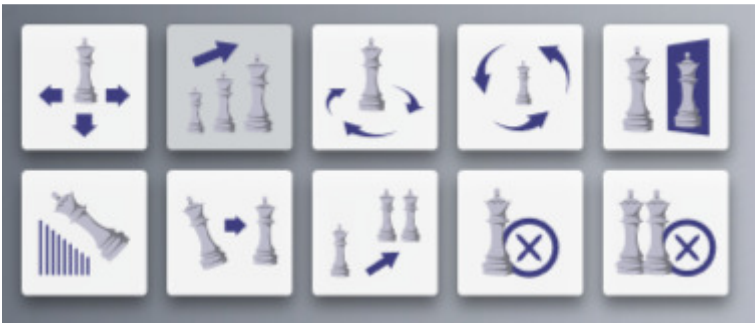

Ved at trykke på knappen med tandhjul på kan settings menuen åbnes. Inde fra denne menu kan de mere tekniske aspekter a 3D printet kontrolleres. En af de vigtigste egenskaber ved denne menu, er at man kan

vælge mellem forskellige prædefinerede opsætninger af printerens. Dette kan man gøre fra højre side af menuen, der hvor der står: High Quality, Recommended og sketch. Ved at dobbeltklikke på disse kan man vælge mellem forskellige typer print: Nogle langsomme men af høj kvalitet, og andre meget hurtige print. Recommended giver ofte det bedste kompromis mellem kvalitet og print tid, og er den fortrukne til skolebrug.

En anden funktion der kan benyttes er "Object strength", hvor slideren nedenunder kan bruges til at bestemme hvor massiv det printede objekt skal være. Husk dog på at et stærkere print vil tage længere tid,

og bruge mere materiale. Materialeforbruget og tiden kan aflæses øverst på skærmen:

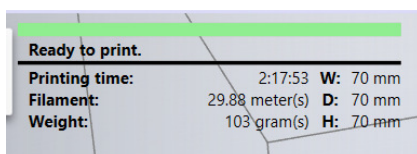
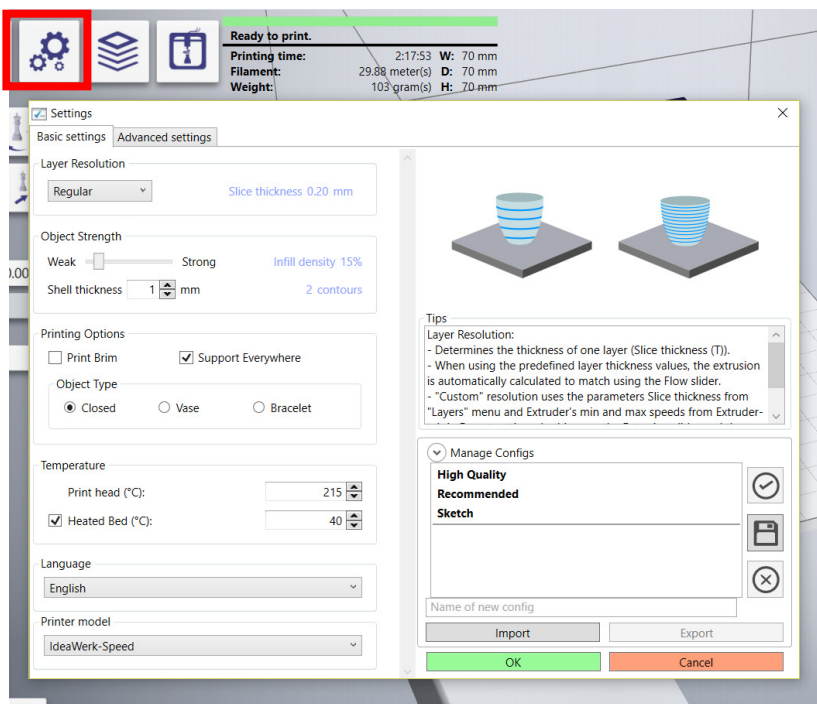

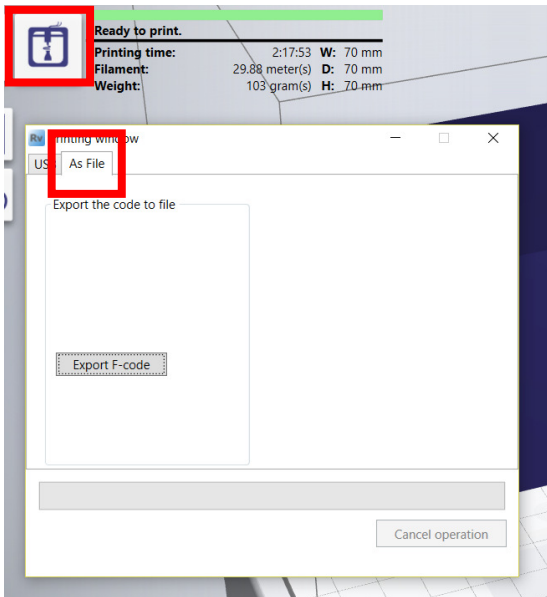

Når man er klar til at printe sit objekt ud skal man trykke på print knappen, og når printvinduet dukker op skal man vælge "as file" fanen hvis man vil printe vha. USB nøgle. Herefter trykker man på Export F-code knappen, og gemmer F-koden på ens USB nøgle. Herefter indsættes nøglen i printereren, og printet kan nu begynde.

Introduktion til motorvejsbroer

For at træne elevernes evne i problemløsning og innovation skal eleverne arbejde med en case fra virkeligheden.

Vi har lavet en opgavebeskrivelse som du kan give dine elever efter du har præsenteret opgaven, den kan findes på de næste to sider. Vi har også tegnet nogle modeller af lastbiler og personbiler som i kan bruge til at teste størrelsesforholdet med. Størrelsesforholdet er valgt da modeller i den størrelse vil tage omkring en halv time til 40 minutter at printe.

Vi anbefaler at du ikke viser dine elever 3D modeller af broer før forløbet da det vil påvirke deres process.

Sæt Senen

Du kan starte forløbet med at vise nogle klip fra broer der er styrtet sammen for at understrege at det er vigtigt at teste og udvikle en bro så man er sikker på at den kan holde til forskellige påvirkninger. Her er en artikel + video om en motorvejsbro der er styrtet sammen i nordjylland lige omkring Aalborg:

<https://www.dr.dk/nyheder/regionale/nordjylland/10-aar-siden-brokollaps-svend-overlevede-fald-paa-syv-meter>



Du kan også vise dette fascinerende klip om en bro fra USA som er gået i svingninger grundet dårligt ingeniørarbejde:

https://www.youtube.com/watch?v=IXyG68_caV4



Kontrakt i udbud fra Transport og Bygningsministeriet

16 motorvejsbroer er ved at blive forældet, vi skal derfor have bygget nye inden de styrter sammen.

Krav:

Broen skal være så billig som mulig og samtidig være stærk.

Der skal kunne køre 4 lastbiler ved siden af hinanden under broen og 2 person biler ved siden af hinanden over broen.

I skal 3D printe en model, der max må være 10x10x10cm.

I skal bruge målestoksforholdet 1:500 når i designer jeres model.

Når I er færdige med jeres model skal I regne ud, hvad den koster.

Derefter stresstester vi den med vægte. Derefter får i mulighed for at forebedre jeres design. Det er vigtigt i kan redegøre for hvordan jeres design har ændret sig og hvorfor i har valgt at lave disse ændringer.

De mål og priser I skal arbejde med står på næste side.

I skal herefter op foran ministeriet og overbevise os om, hvorfor det lige præcis jeres bro der er den bedste.

Det Entreprenør firma der laver den bedste vinder kontrakten

Mål og Priser til brug af udregning

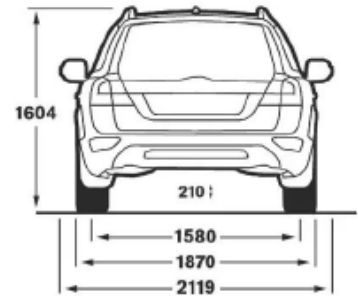
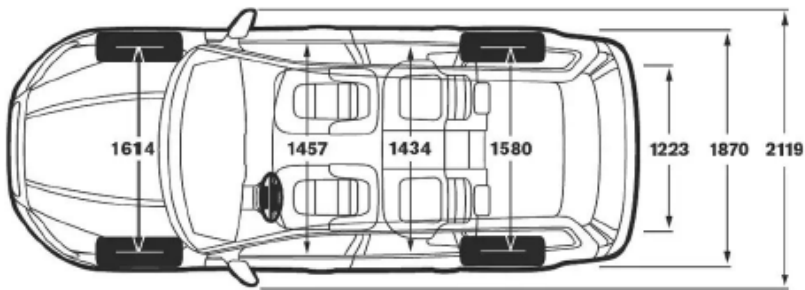
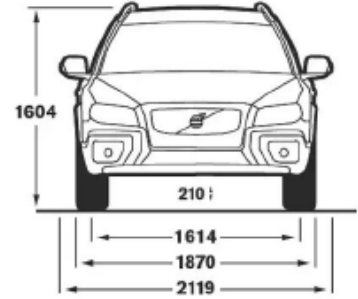
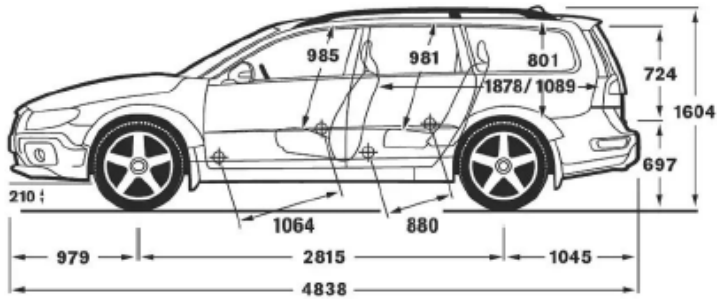

Pris for stålfiberbeton 1.831kr pr m³

Gruppearbejde

Under gruppearbejdet vil eleverne gå igennem 3D printerprocessen flere gange. Der er her en guide til hvordan i kommer igennem de forskellige trin i processen.

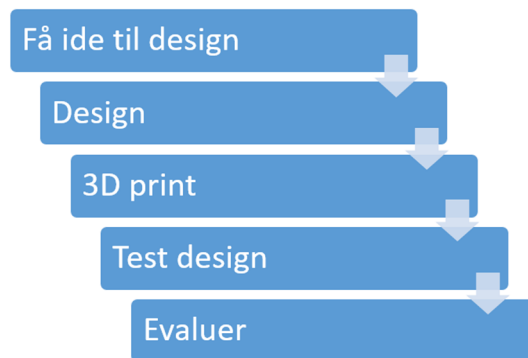

Gruppearbejde og Print tid

Når eleverne arbejder i grupper træner de deres evner i kollaboration, da eleverne kan hjælpe hinanden og evaluere sammen. Gruppearbejdet gør også at ventetiden til at få sit design bliver bragt ned. Optimalt har hver gruppe deres egen 3D printer til rådighed. Hvis der kun er adgang til én 3D printer kan forløbet med fordel deles op, således at der kan printes imellem lektionerne.

Man kan også sætte krav til hvor lang tid elevernes designs må tage at printe. Dette kan aflæses i REAL vision og bringe en ekstra dimension ind i opgaven.

Få ide til design

Eleverne skal først have ideer til deres design. Lad dem reflektere over hvad der skal gøres deres design specielt og hvilken målsætning de har med deres design: skal det være billigt, holdbart, smukt eller have en helt specielt funktion.

Nogle elever har svært ved at få ideer, her kan du foreslå dem at søge information på internettet, en enkelt google søgning kan give meget inspiration. Ellers kan eleverne kigge på siden <https://www.thingiverse.com/> hvor folk deler deres 3D designs. Bemærk dog at der hurtigt kan opstå en "plage" effekt hvis eleverne går på thingiverse, hvis de får lyst til at 3D printe nogle af de flotte designs på hjemmesiden.

Design

Eleverne laver deres design i et design værktøj. Du kan finde en guide samt tips og tricks på side 5.

Test af design

Eleverne skal undersøge hvor meget deres design af bro kan holde til. Hvis eleverne selv finder ud af en metode til at måle broens holdbarhed og notere det ned træner de deres evne til videns konstruktion. Alternativt kan Du finde nogle vægte de kan bruge til test, dette kræver forholdsvis tunge vægte, omkring 40-70 kg. Hvis du ikke har vægte kan andre materialer bruges, så længe at vægten gradvist kan forøges. At vægtene gradvist kan forøges, vil nemlig medføre at akselen får en god opløsning.

Evaluering af design:

Til at hjælpe eleverne med at evaluere på deres design kan du bruge et stort koordinatsystem (A2) hvor eleverne kan placere deres design. Dette kan træne elevernes evne i selvevaluering, men kan gøres på mange niveauer, afhængigt af hvor meget tid man har, hvor dygtige eleverne er, hvor faste krav der er sat til deres designs mm. Her er der nogle eksempler på hvordan koordinatsystemet kan bruges: Akserne er forudbestemt af læreren, dermed ved eleverne hvilke parametre deres design bliver bedømt på. Hvis y-aksen er holdbarhed i Kg, og x-aksen er materialeforbrug, kan eleverne efter test og udregninger

placere deres bro i koordinatsystemet. Herefter kan eleverne overveje hvilke parametre de skal justere på for at forbedre deres design: skal den være billigere, skal den kunne holde til mere? Eleverne kan med fordel dokumentere deres overvejelser.

Er akserne ens for alle giver det mulighed for at eleverne kan sammenligne deres designs med andres, samt peer-evaluering undervejs i forløbet.

En anden mulighed er at eleverne selv navngiver akserne alt efter hvad der giver mening for dem og hvilket mål de har for deres design. Måske ønsker eleverne at lave en billig bro eller måske er det vigtigere for dem at broen har et smukt design. Eleverne kan med fordel dokumentere deres overvejelser.

Løbende vil eleverne kunne se hvordan deres designs har udvikles sig over tid. Husk at der skal tal på akserne, men at disse kan "flytte" sig alt efter hvordan designet udvikler sig.

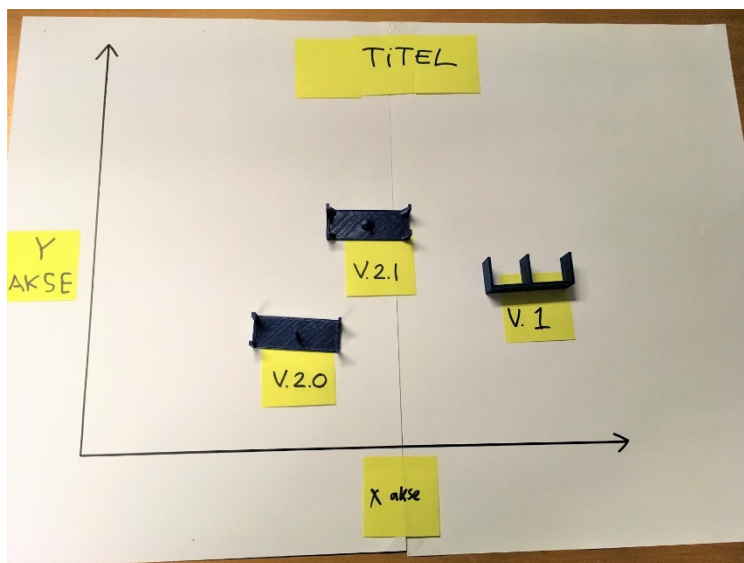

Elevernes dokumentation af forløbet:

Eleverne vil have gavn af at dokumentere løbende, specielt hvis det strækker sig over flere dage. De kan med fordel lave en mini udgave af koordinatsystemet som bedre kan være i tasken. Det er vigtigt at eleverne kan redegøre for hvordan designet har ændret sig over tid, og hvilke grundlag der har været for at foretage disse ændringer, samt om ændringerne havde den ønskede effekt.

De kan blandt andet notere følgende:

- Hvilke egenskaber har jeres design nu?
- Hvilken egenskaber ønskes det at fremme i næste design?
- Hvilken ændringer har i lavet for at fremme disse egenskaber?

Afsluttende fremlæggelse

Eleverne afslutter forløbet med en kort fremlæggelse eller en pitch. En pitch bruges når entreprenører skal fremlægge deres ideer. Efter alle eleverne har fremlagt vælges det bedste design og kontrakten" skrives under". Man kan med fordel have en udefrakommende dommer på besøg.

Hvad indeholder en pitch:

Der er her en kort guide på engelsk i hvordan man laver sådan en elevator pitch:

https://www.youtube.com/watch?v=y1Y02_oZP8U . Men kort sagt er formålet at elever kan kommunikere kort og præcist:

- Hvad der gør deres løsning unik

- Hvordan deres løsning har udviklet sig i processen

- Hvilke omkostninger der er ved deres design

Læringsmål under forløbet

Når dette forløb bliver kørt som beskrevet bruger, træner eller udvikler eleverne forskellige kompetencer. Dette afsnit beskriver hvilke kompetencer som bliver opnået i de forskellige dele af forløbet. På den måde kan du afkorte eller forlænge forløbet og stadig vide hvilke af de Fælles mål eleverne tilegner sig. Eleverne benytter sig en del af matematiske kompetencer, men hvis du ønsker at eleverne med sikkerhed skal opnå disse kompetencer igennem dette forløb anbefaler vi at matematikken bliver tydeligt italesat.

Naturfaglige mål

Undersøgelse: Når eleverne skal teste holdbarheden af deres bro, vil de designe og gennemføre et forsøg. Det store koordinatsystem skal hjælpe eleverne med at evaluere på deres resultater.

Modellering: Den 3D printede bro er en model af virkeligheden. Efter at have undersøgt og evalueret på holdbarheden af deres design, vil de vurdere hvordan den kan forbedres.

Perspektivering: Eleverne arbejder med en case fra omverdenen. De relaterer deres arbejde igennem evalueringen af broens design samt når de udregner dens pris. Forløbet afsluttes med at eleverne kommunikerer deres resultater ud til omverden.

Kommunikation: Under evalueringen øver eleverne sig i at kommunikere om de naturfaglige værktøjer med deres gruppemedlemmer. Det store koordinatsystem er en god hjælp hertil. Forløbet afsluttes med at eleverne kommunikerer deres resultater ud til omverden.

B.1 The Current Version of the Guide

THE ITERATIVE DESIGNER

An approach for structuring a learning activity with a
3D printer

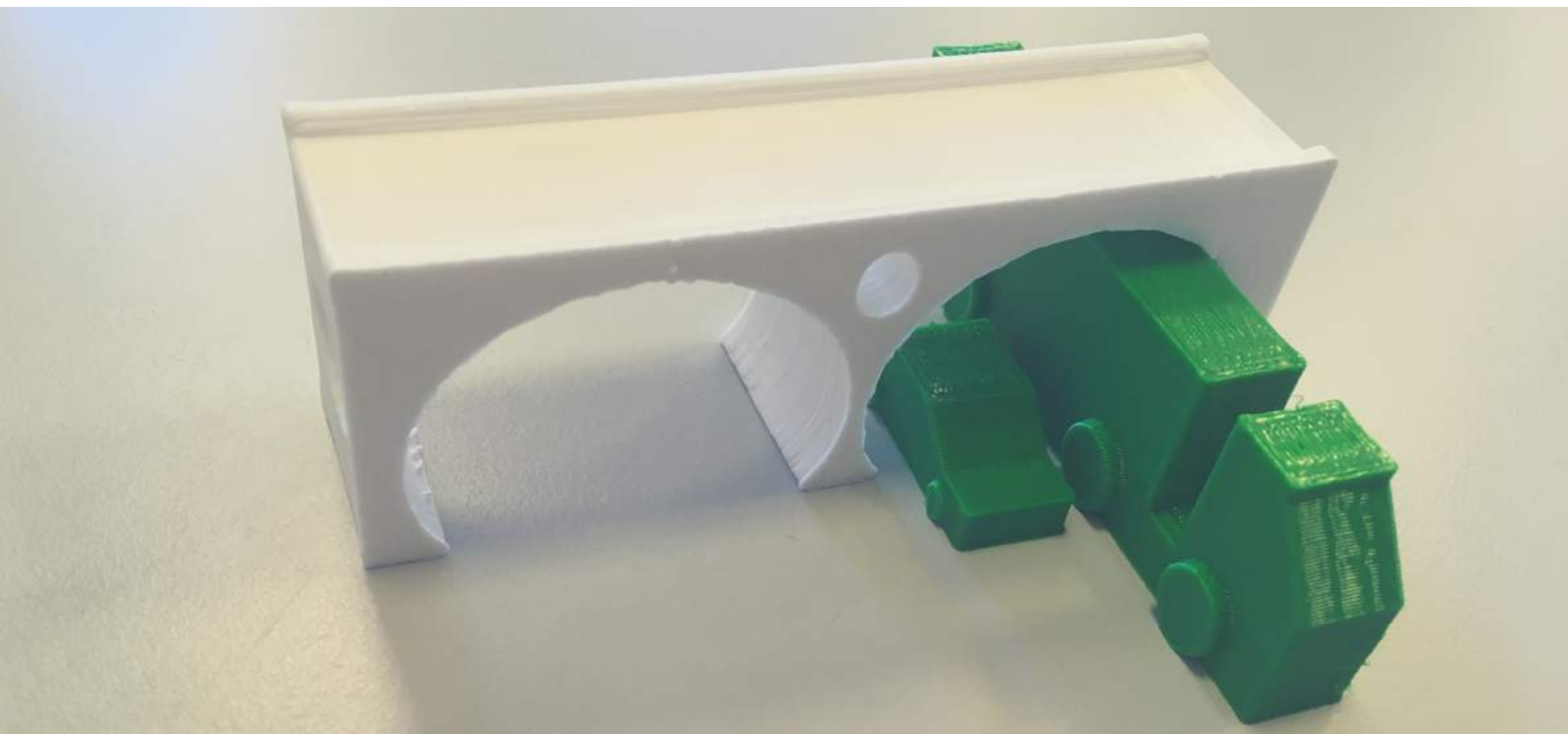

Author

Anders Bod Lund
Helga Negendahl Madsen

INTRODUCTION

Understanding the iterative process

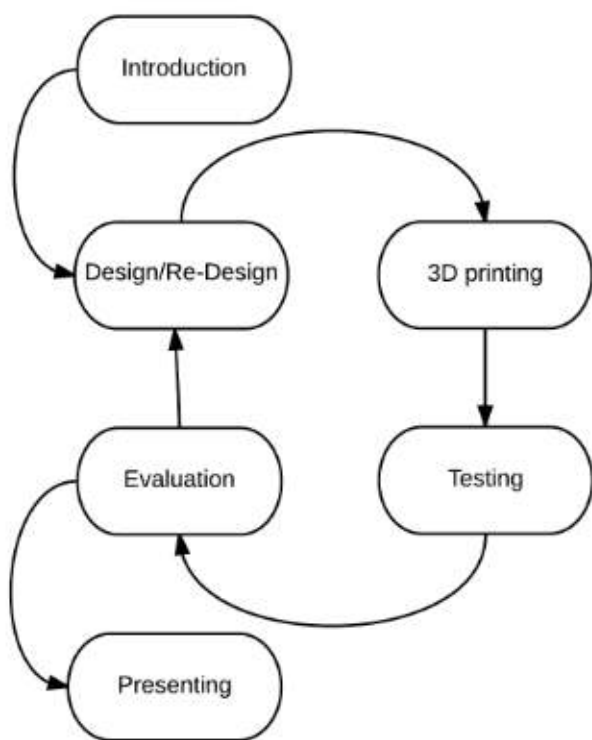

The Oresmian Coordinate System

by Anders Bod Lund & Helga Negendahl

This is a guide to structure learning activities where the pupils go through an iterative process to learn how designs can be developed and improved over time. This way of structuring a learning activity will require the pupils to use a tinkering mindset to learn how to fail fast and succeed sooner. Through the learning activity the pupils will use and develop their 21st century skills and can explore a variety of STEM fields.

Your role as a teacher is to guide the pupils through six phases and help them construct knowledge to improve their design. First you will introduce the pupils to the design task, hereafter the pupils will begin the iterative process and design a solution. When the pupils are finished with their design they will 3D print it and hereafter test it. After the test the pupils will evaluate their design by using a coordinate system, which will help them understand and get ideas of what they need to change in order to improve their design. The next step is to implement these ideas in the re-design phase and then go through these four phases as many times as possible to continuously test and improve the design. At the end of the activity the pupils can present their product, but also the process they went through to achieve it. On the following pages, you will find a guide to run all these phases smoothly and some suggestions for design tasks you can give your pupils.

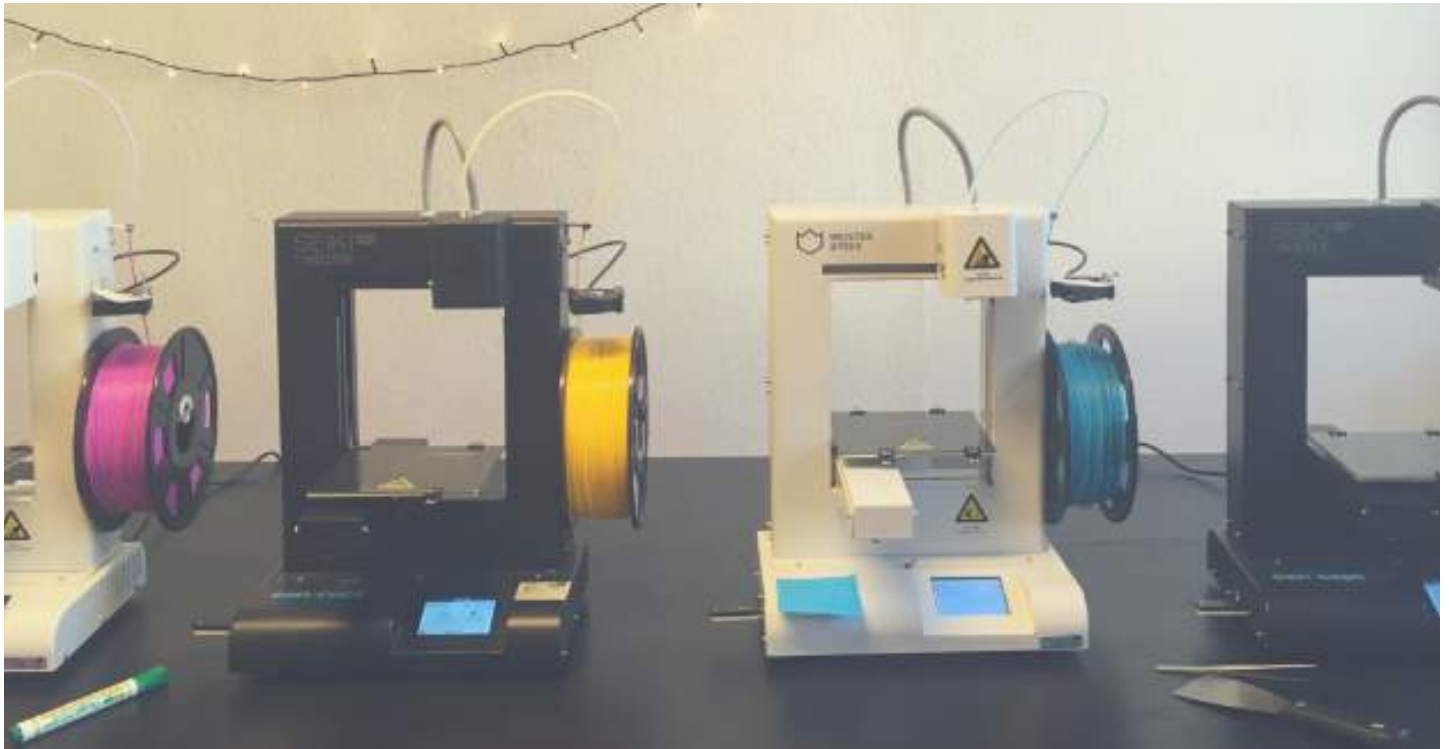

Planning the Learning Activity

Before the learning activity some practical considerations should be made:

Group work -Group work is an advantage when designing and 3D printing. It will help the pupils develop their collaboration skills and it gives them the possibility to discuss complex problems and help them come up with new ideas. It is often an advantage to have 2-3 pupils in one group to make sure that there are enough tasks for everyone, but the optimal group size will depend on the task at hand.

Printing capacity -To have the pupils go through an iterative process, it is suggested to have one printer per group. In this way the pupils can control the printing process themselves, and have the possibility to go through an iterative process. A tip is to use different colored filament on each printer which makes it easy to see which group produced which design. Also, having fast 3D printers helps make the iterations shorter, and thus increasing the learning potential.

Knowing the tools -The pupils will be in charge of the entire process themselves, however they might need help with the design tool and with managing the 3D printers depending on their previous experience with 3D printing. Therefore you as their teacher need to have a good understanding of the design tools and the printing in order to guide the pupils.

Time -The learning activity involves an iterative process where the pupils will immerse in their work. Therefore this type of learning activity is most suited for a whole day activity.



In this exciting approach the pupils will take on the mindset of an engineer by continuously innovating and evolving their designs!



Introducing the Task

The learning activity starts with the teachers introducing the task and the tools. Keep the introduction as short as possible, the pupils need to make their own experiences and will learn through this, however, some information is essential for starting the learning activity.

Introduce the Tools -The pupils need to know what a 3D printer is and which design tool they should use, if they do not have previous experience with it. If not they might need to get a short introduction to what 3D printing is and how the design tool works. We prefer to use Thinkercad as design tool since it is easy to learn. It can be an advantage to wait with the introduction on how to start a print until the pupils are actually about to start their first 3D print.

Introduce the Process -Before the pupils start working they need to know that they are working in through several iterations, and that the learning activity extends beyond the initial print. Explain to them how they are going to design, print, test, evaluate several times to keep exploring and improving their design. They also need to know what to do in each phase and how much time they have, in order to be able to regulate their process themselves.

Introduce the Task -Finally the pupils need to know the design task and which problem they are solving. Finding a good design task can be hard, and several considerations are necessary. First of all it is an advantage if the object is small and fast to 3D print, being able to print it within an hour is an advantage. Furthermore, the task should be to solve a problem, but with multiple possible approaches. This can be easier for the pupils if the task contains some constraints or goals which gives the pupils a direction for their design.

The picture is an example where pupils have designed mobile covers for an iPhone. Through three iterations they adjusted their design. Notice that that in the first version the camera hole is placed on the wrong side.

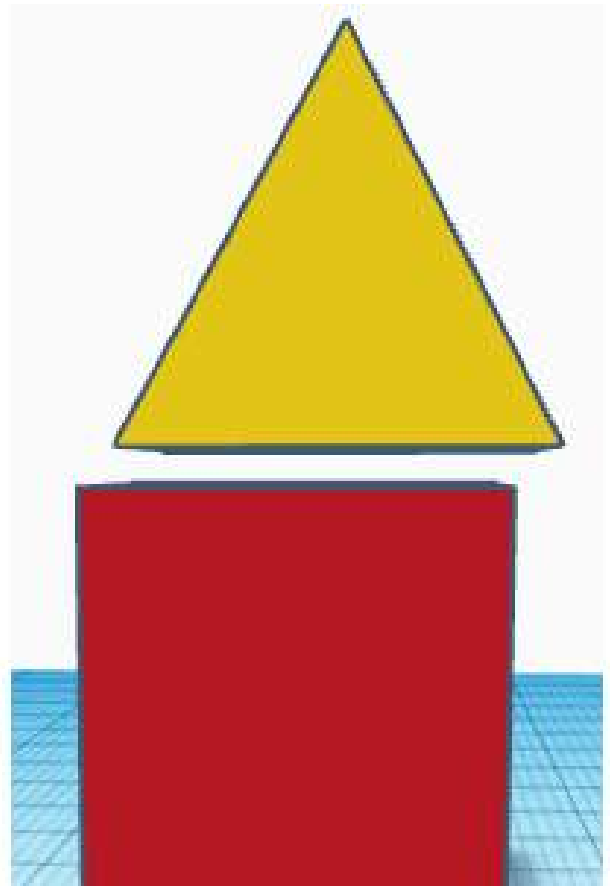
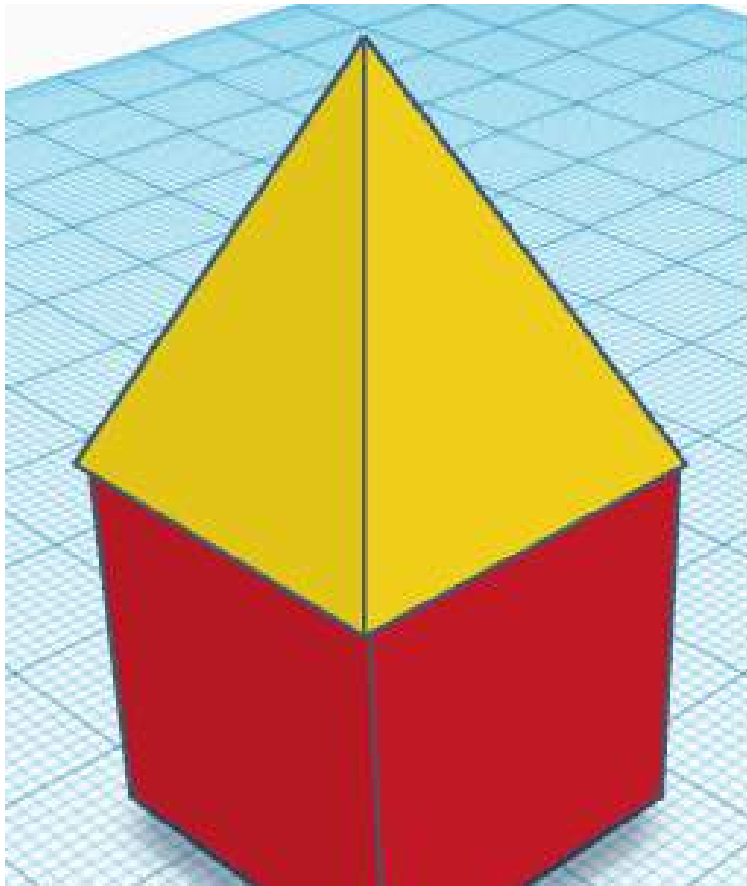

Designing

When designing the pupils will mostly work in their groups. The goal is for the pupils to work individually, and regulate their own design process in this phase. However, you as a teacher can expect help in a variety of different ways.

The groups will all need at least one computer with access to the design tool, and the slicing tool for the 3D printer. More computers can be an advantage, although working together on one design rather than every member working on individual designs should be encouraged, since it, in our experience, provides the best environment for team work and learning.

A part of this learning activity is to have the pupils learn from their mistakes, and they should print some things that do not work, and see for themselves exactly why. However, there is a list beneath of some beginner's mistakes that can be avoided before printing:

Floating elements – If some elements float in the air rather than being attached to objects underneath, the print will most likely fail. Help the pupils check the design by rotating the camera in the design tool to see it from all angles. If there are floating elements the pupils will be able to spot and fix it themselves before printing (see picture).

Time consuming prints – The pupils will in any case spend some time waiting on their design to be 3D printed. If a design takes more than one hour to print the pupils are in danger of losing their motivation and focus. Therefore, we suggest that the pupils are encouraged to keep their prints short, however, the pupils can sometimes also regulate their own process, and assess which printing times are acceptable for them.

Tinkercad is a free tool suitable for both beginners and novices. On youtube you can find guides to get you and your pupils started!

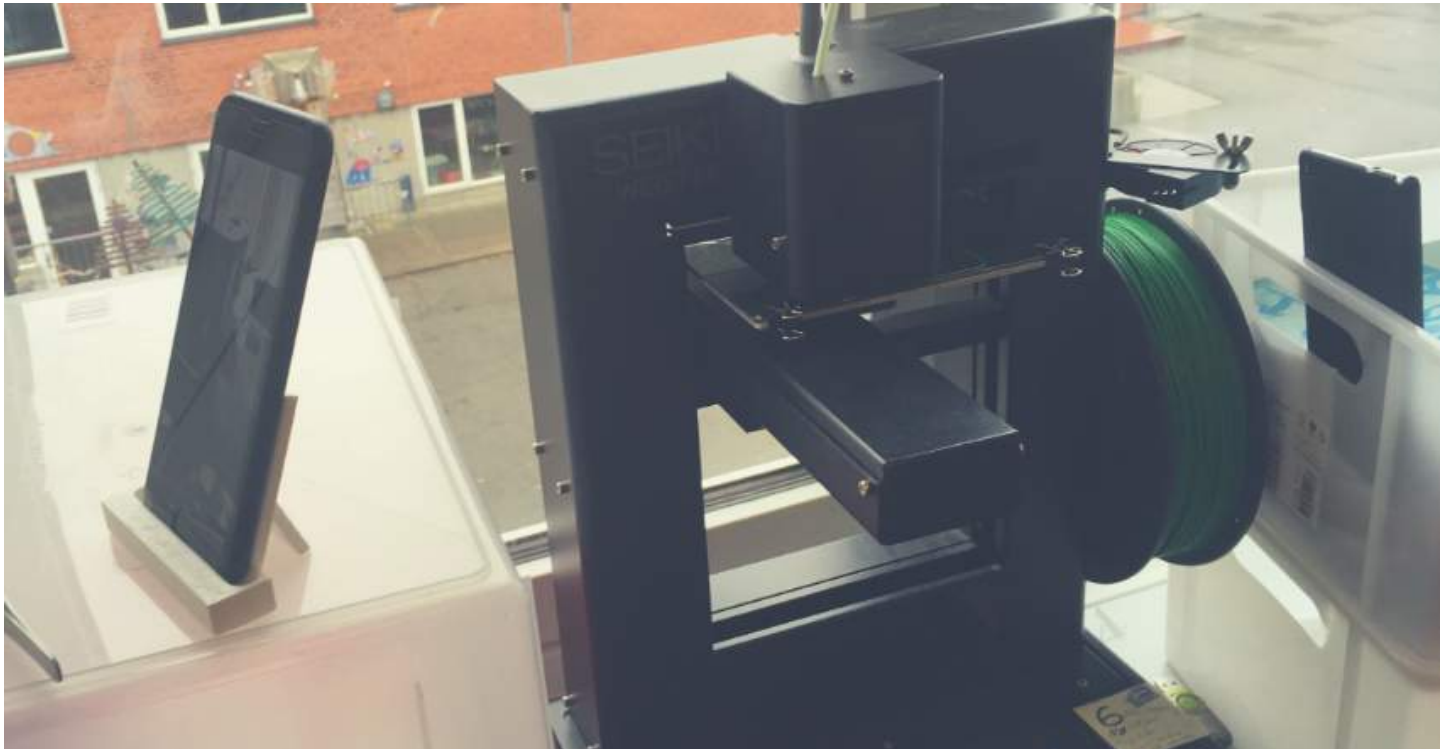

3D printing

The pupils should be in control of printing their own objects, this will give them an understanding of the technology and the fabrication process. They also need to learn the limits of the 3D printer, which types of designs to avoid and to consider if the design can be rotated in order give a better result of the finished design. This involves spending time teaching them how to start the 3D printer, but in the long run this will save time compared to having to start all the prints as the teacher. Having the pupils in control of the printing process teaches them to self-regulate and plan their time, and you can focus on teaching rather than providing tech support. It can be a good idea to encourage the pupils to print their iteration rather fast, so the other phases are introduced, and they get a feel for the iterations. There is always time to add more in the future iterations.

When the 3D printer is started, there will most likely be some waiting time. This time can be spent on making some calculations, like price, material usage, or volume of the design. However, there might still be some time to spend, and this time can be used for break. However, that demands that they pupils can have a break without disturbing others, since other classes might not have a break at the same time. However it will train the pupils' ability to self-regulate since planning their own breaks is a part of planning their work. Just remember that the pupils are just starting to learn how to self-regulate and they might need your guidance. .



3D printing allows novices to create products with a professional finish and can turn ideas into reality

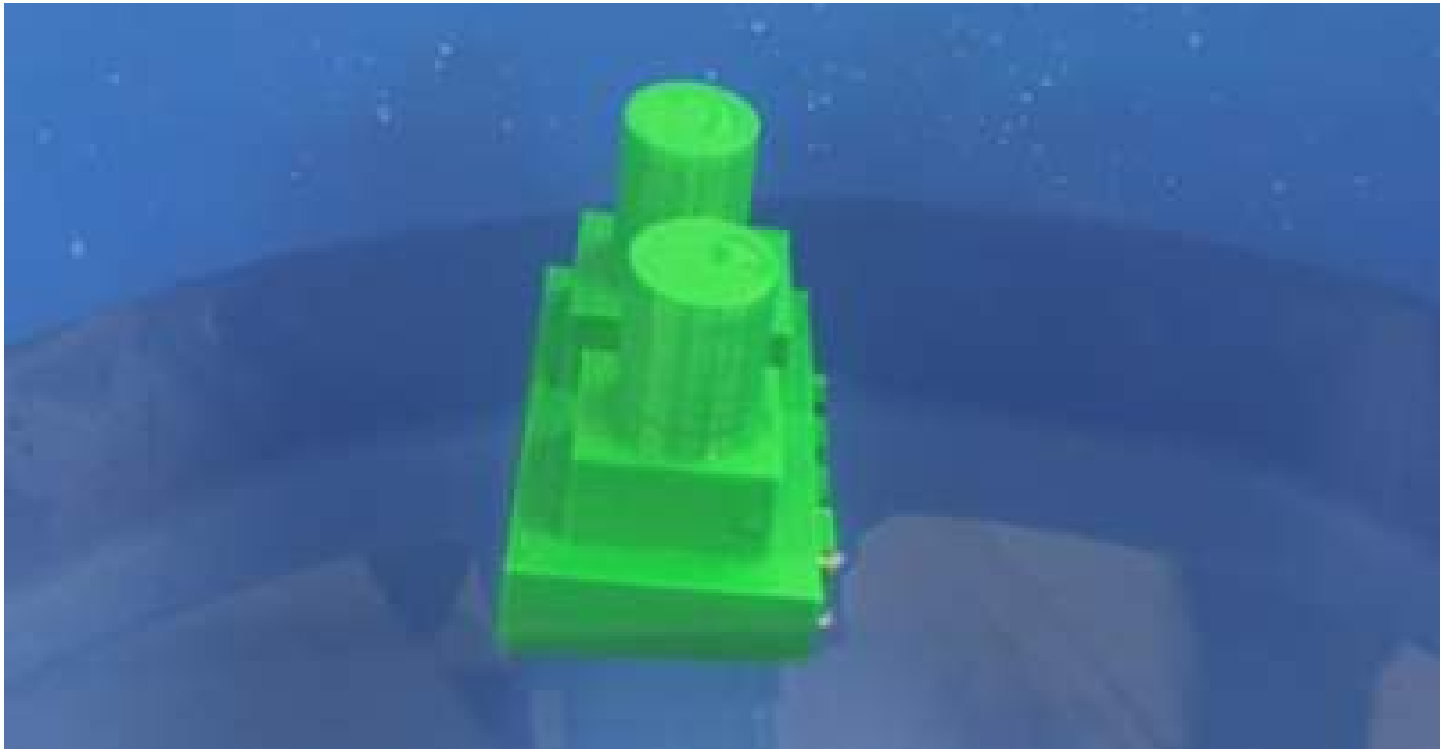

Testing

In this phase, the pupils will test their design. The purpose is to let them investigate their design to figure out how to improve it. This will most likely demand your presence to help understand and interpret the result of the test.

The way of testing will depend on the object, the task, and the goal of the activity. It is very important that the test helps the pupils investigate how well their design meets the requirements of the task. It should be a test which shows the flaws and weaknesses of their design and helps them get ideas on how to improve the design. This could be that they should make a design that is sturdy, and therefore test the durability or strength of their design. Having this type of test will most likely result in broken prototypes, however, that is not a problem if the pupils don't feel a strong personal connection to the object and they know that they have time to print a new prototype. Furthermore, most of the pupils will find it fun to break their design.

In contrast to the design phase the test can be more social, and one "test station" where the pupils can take turns in testing can be enough, depending on the size of the class. The groups can benefit from paying attention to the results from the test of others, and having a common test station will invite them to observe and maybe even interact with other groups, promoting collaboration between them. The test will help the pupil construct knowledge in order to solve problems. On the pictures two examples of testing can be seen. The first shows a test of a boat-design, the test makes it visible that the boat is off balance. On the other picture some pupils are testing the strength of a bridge. They have designed and 3D printed a 1:500 model of a Highway bridge and are now using stacks of paper to test how much weight it takes to brake the model. Afterwards they will examine the broken prototype to see where it needs improvement.



Testing is a fun way of getting instant feedback on the performance of a design, and is essential for further development.

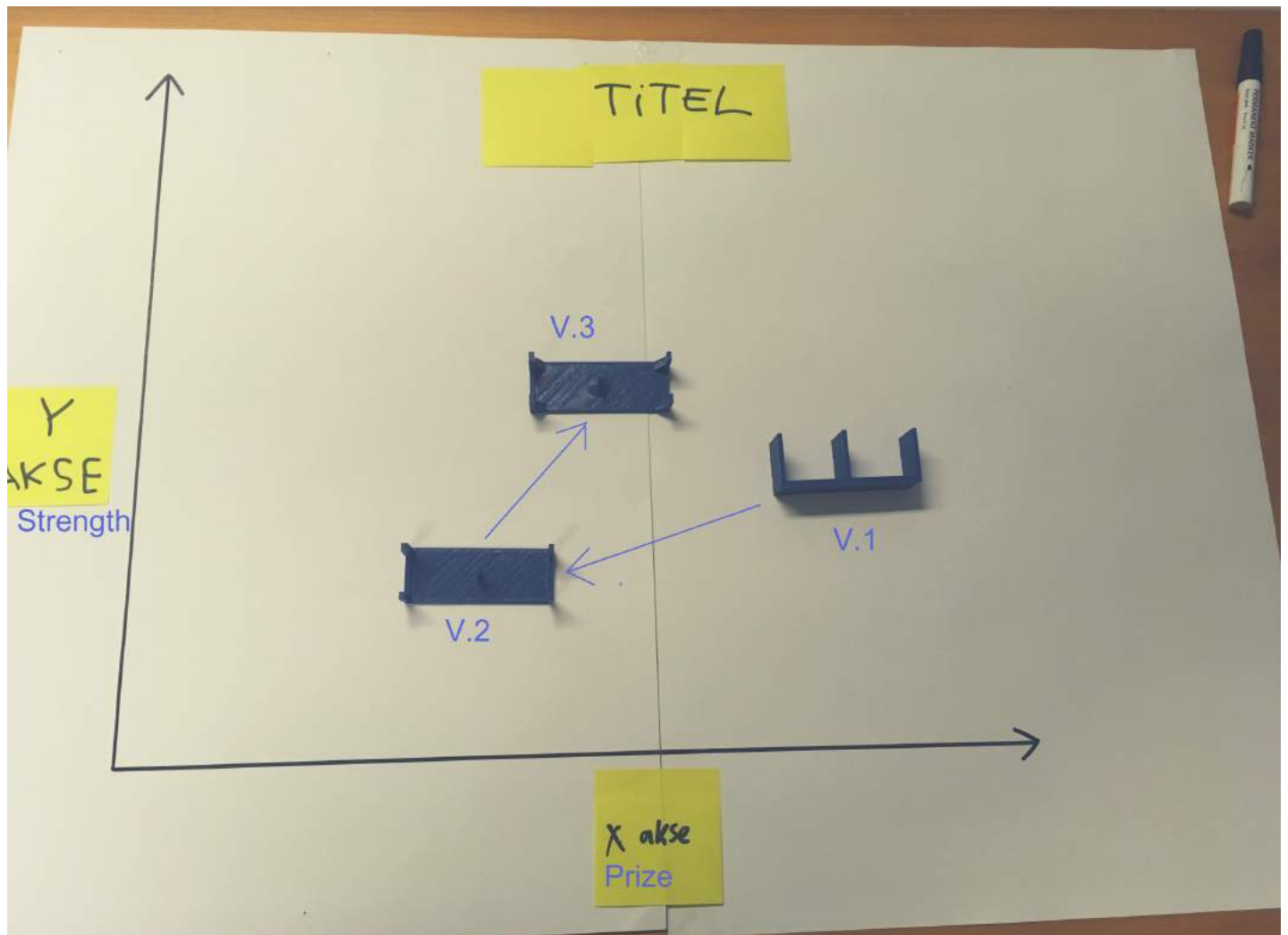

Evaluation of design

After the test the pupils will need to evaluate their design, and this can be done using a coordinate system. This is a tool that can give the pupils a visual idea of how well their design is performing which will help them in a self-regulating process.

You or the pupils decide which units to use on the coordinate system depending on what makes sense due to the design task. If the pupils are asked to design something with low cost one of the axes could be material use or price. The axes will indicate which parameters the design, are measured on which will help start a dialog about how the design can be improved. However, the pupils might need your guidance to place the 3D print correctly and go through a reflection in order to determine what to focus on, in order to improve their design.

Over time several versions, or prototypes, will be placed on the coordinate system, which will show the development and process of the design. If several groups are working on the same design task they can use the same coordinate system. On the picture models of bridges are placed on a coordinate system, the goal is to make a strong bridge with low cost, in three iterations the pupils have improved their design and moved toward the top-left side of the coordinate system.

The coordinate system is a flexible tool, and you can easily adapt it to your own learning activity. By changing the axes on the coordinate system the learning activity can be aligned to many curriculum standards.



Making the Coordinate System

The coordinate system is made by drawing the two axes, preferably on a large piece of paper. The coordinate system is a flexible tool, and, by writing units and numbers on post-it's it is possible to change the units and scale of the coordinate system if necessary. Also, it can be very useful to write data on post-it and then place the 3D printed designs on top of those, this makes it easier to see, and remember, how a design is placed. If the 3D printed design breaks under test, just place whatever remains. Having the coordinate system on the teachers table, will invite other pupils to participate in the activity.

If the pupils have no previous experience with using the coordinate system to evaluate their design, you have to decide units and size of the axes. The easiest way to use the coordinate system is to give the pupils two parameters, in the design task and create the axes after that (like with the bridges). If doing that, remember that these constraints should give the pupils a direction but not an ultimate goal, by giving them a direction they will always have the possibility to improve their design. This type of design task and way of using a coordinate system trains the pupil's ability to problem solve.

However, the coordinate system can also be used to construct knowledge. In the picture below a pupil are designing a spinning top, and the goal is to have a long spinning time, which is the unit on the Y-axis. The x-axis is the weight, which leads to the pupil to discover that the heavier the spinning top, the longer the spinning time. Therefore, careful consideration should be done when selecting the axes as it will have profound influence in the kind of learning that will take place.

The coordinate system can be used to make a design phase continous. A design can always be improved on one of more parameters, and there is no such thing as a final version – just like in real life produkt development



Presentation

After having gone through several iterations the pupils will end the learning activity with a presentation of their work. There are different ways of doing this depending on which learning goals the pupils should achieve. The pupils use ICT systems in their presentation in order to improve this skill. The pupils can also work on a short elevator pitch presentation, where the pupils give a short sales talk on why their product is the best. Another possibility is to have them working on a written assignment, or even a multimedia presentation.

However, it is important that by the end of the activity the pupils get to reflect on the process as a whole

The coordinate can be used in the presentation to explain the process of developing a product. How did you come from one version to another? Why did you make the changes you did, and how well did they work?

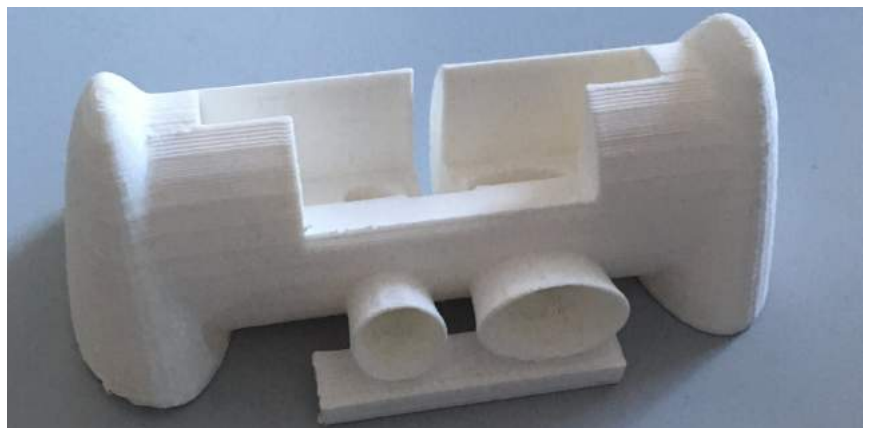

DESIGN HIGHWAY BRIDGES

Learning activity guide

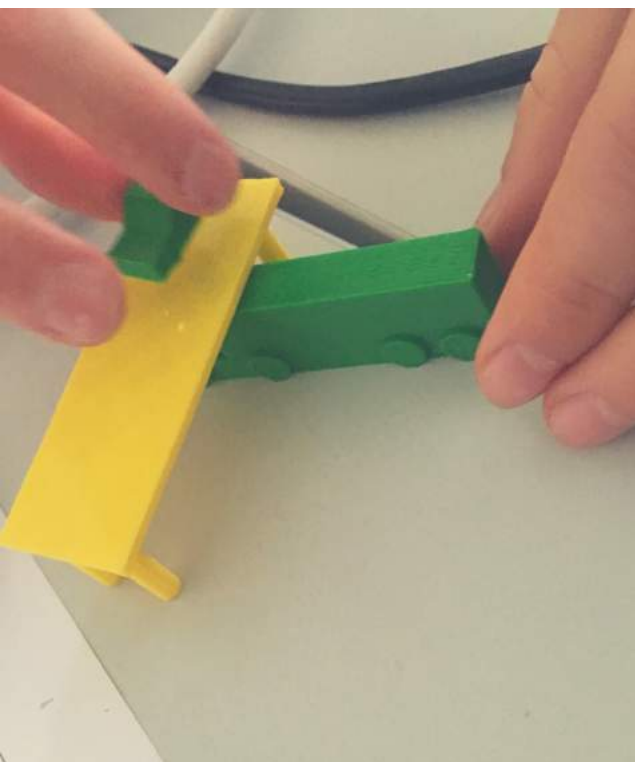

Materials

1. Preferably one 3D printer per group
2. Printed models Trucks and cars in the right model size.
3. The STL-files of trucks and cars in the right scale to help the pupils design
4. One test station with heavy weights
5. A coordinate system large enough to share

Introduce the task and let them design

In this learning activity, the pupils will develop a design for future highway bridges through an iterative process in groups of 2-3. In the end, they will make a short presentation of their work. This learning activity can work well as an introduction, if either you or your pupils are new to 3D printing.

Introducing the design task

In this task the pupils will design a highway bridge where two cars can drive over and four trucks, two in each direction, can drive under. The bridge must be as strong as possible to avoid accidents and collapses, however, the price must also be taken into count.

Designing

Designing in a 1:500 scale produces bridges of an adequate size an allow pupils to compare, both with their own previous designs but also with others. It will be an advantage to give them models of trucks and cars in the right scale, you can draw them to practice your own skills in the design tool, or you can use the predefined models. These can be used for the pupils to "design around", which will ease the design process and help them start the 3D printer sooner. However using these models will limit their use of math, so you have to decide on the learning goals for the activity.

3D printing

Another reason on why the pupils should design a 1:500 scale model of their bridge design is to keep the printing time down. Teach the pupils how to start their own prints so they can be in control of the process. Often the bridges need to be rotated in order to be 3D printed properly, and this is a good opportunity to introduce this concept to the pupils. If you do not have any experience with the printer, you can practice by 3D printing the truck and car designs.

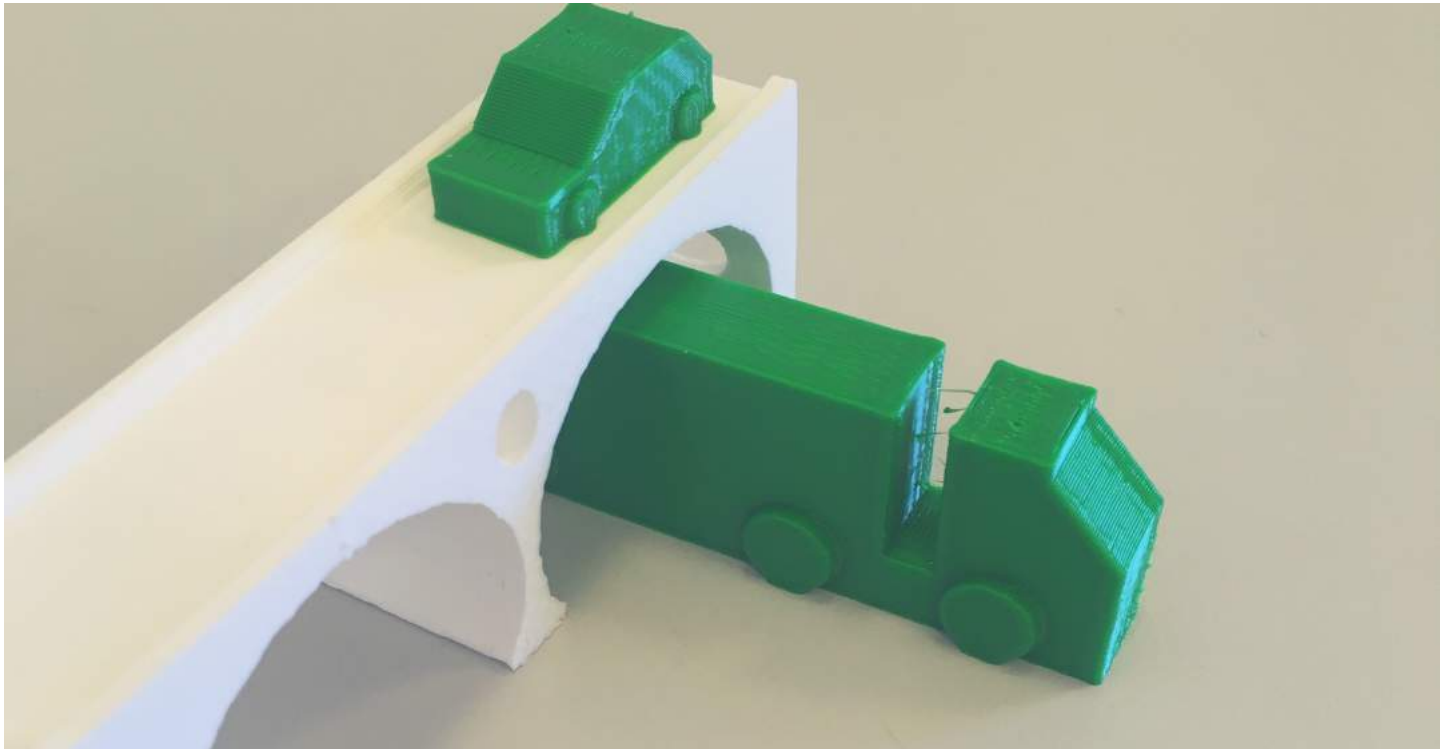

Calculate the price:

While the model is being printed the pupils can start to calculate the price of their real-life-bridge. The pupils might need help first time they are doing this. There are different approaches to calculate the price, we start by finding the volume of the print, by seeing the 3D printer as a machine which arranges a long cylinder (the filament) into a new shape (the design). When starting the 3D print the program will most likely inform you about the length of filament which will be used on this design, which the height (h) of the cylinder. On the spool of filament you can find the diameter (most likely 1,75mm or 2,85mm), which can be converted into the radius (r).

$$\text{Volume of Cylinder (model of bridge)} = \pi \cdot r^2 \cdot h$$

The Volume of the Cylinder should be calculated in cubic meters, since this will be useful when we know the price of one cubic meters of concrete. Therefore, the next step is to multiply the volume with 500³, to get the volume in the right scale on all three dimensions, since we are designing in 1:500 scale.

$$\text{Volume of Bridge} = (\pi \cdot r^2 \cdot h) \cdot 500^3$$

The next step is to multiply the volume of the real life bridge with the price of the material in which the bridge will be built in. We have used a price on Steel Fiber Concrete on 1.831 Danish Kroners pr. m³.

$$\text{Price of Bridge} = (\pi \cdot r^2 \cdot h) \cdot 500^3 \cdot (\text{Price of material pr. m}^3)$$

Remember that you can change this learning activity and plan it to fit your own context and pupils.



Test the strength

After the bridge is finished it is time to test the strength of the model. Therefore, it is important to have the pupils design in the same scale, otherwise they can't compare the designs. In the test the pupils will place weight on the 3D printed model to get an understanding of the durability of their design.

We have used stacks of paper to measure the durability, but other heavy elements would do just as well, just be prepared that some of the bridges hold over 100kg. The pupils can share the weights and take turns in testing the durability of their design. The testing zone is nice to have in a common area so pupils from other groups collaborate and interact during the test.

One of the advantages of designing bridges during a learning activity, and testing them this way is that they will break. The pupils do not have to be afraid of failing, because the purpose is to investigate failures – and learn from them. The bridge HAS to fail, and weight should be added until it breaks.

Some of the bridges can lift more than 80Kg, so make sure you have enough weight to test the limits of the design. Stacks of paper, or fitness weights.

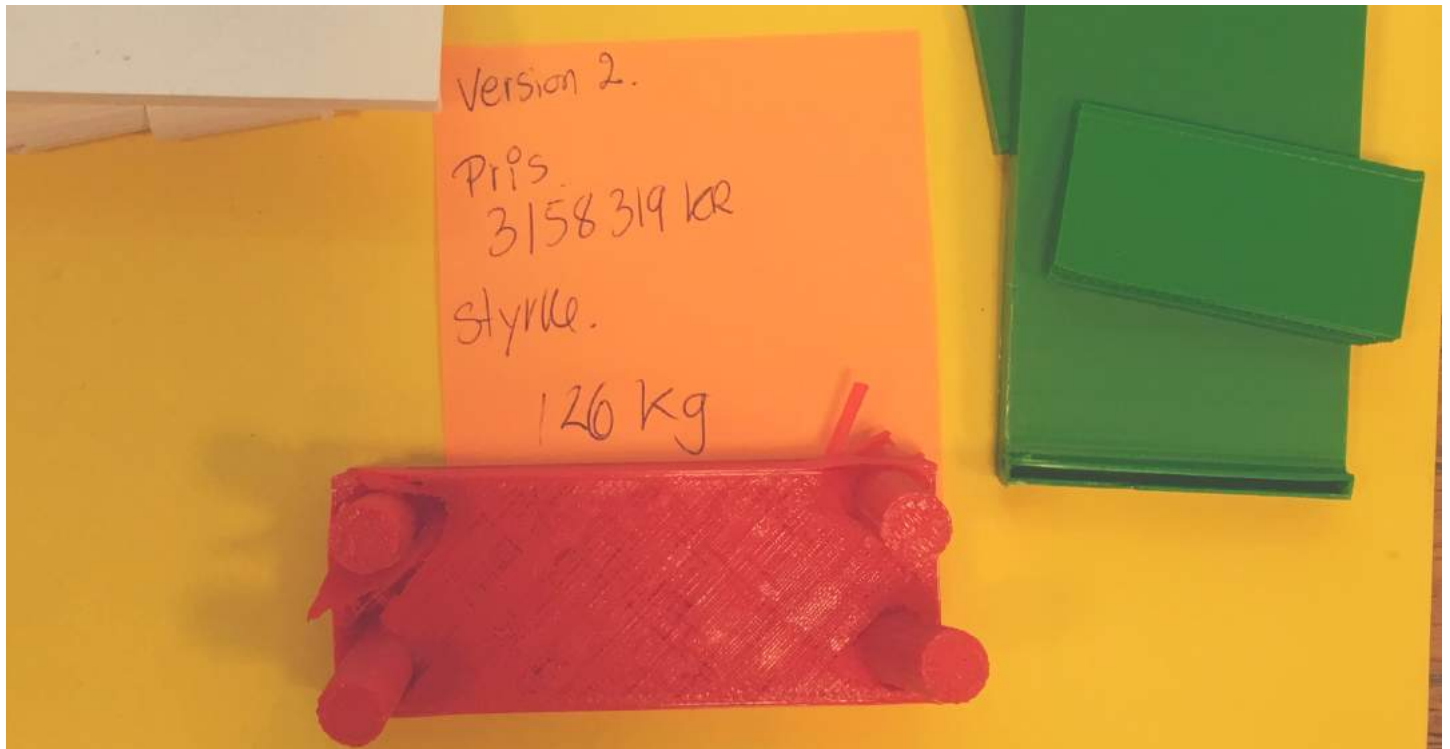

Evaluating and Presenting

When knowing the price of the bridge and the strength of the model the pupils can write it down on a post-it and place it on the coordinate system.

Evaluating their design

The X-axis is the price and the Y-axis is the strength, which means that a strong design with a low price places the design in the top-left part of coordinate system. Help the pupils place their post-it and broken model on the coordinate system, and ask them where they their next iteration should be placed, and discuss what they can do to achieve that goal. This could be to look at weak spots on the design, which will tell something about where the design needs improvement. This is where the pupils learn from the failure, and they should assess HOW their design failed. After the first iteration, the pupils will re-design and go through this process as many times as possible.

Presentation

Before the learning activity are over the pupils will present their designs and their process. Here they should argue which of their design are the best and give reasons why.

The coordinate system can be used to encourage reflection upon the design process.

DESIGN SPINNING TOPS

Learning activity guide

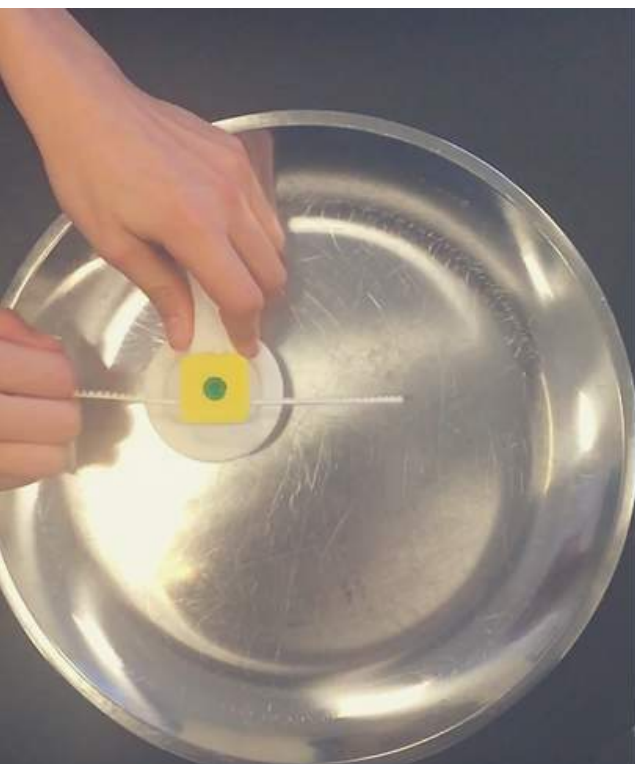

Materials

1. Preferably one 3D printer per group
2. Printed models of the following: Box_lid, lower_box, starter_strip, and starter_gear. These models should not be changed unless the pupils are quite proficient in CAD modelling.
3. The STL-files for modification: spin_blade_bottom, and half_spin_plate
4. At least one Battle Arena
5. A coordinate system for each group
6. A glue gun

Introduce the task and let them design

In this learning activity, the pupils will modify a design of a spinning top from thingiverse: <https://www.thingiverse.com/thing:1395135>. The learning activity will take at least a day. The pupils will work in groups of two or three and collaborate on designing the best possible design.

Preparation

The pupils might know the spinning tops as Beyblades, which are spinning tops that are started with a gear and can “battle” each other, which is done by starting two spinning tops at a time, letting them collide into each other and the last one spinning wins. The groups will spend their day modifying, and improving a spinning top through several iterations. The learning activity ends with the pupils choosing a design to participate in a tournament. It is possible to buy Beyblades Battle Arenas, however, you can most likely find something in the kitchen which can work. As seen on the picture we have used a type of metal dish as Battle Arena, the important thing is that the arena will force the spinning tops to collide. In this learning activity all groups need their own coordinate system. You will also need a hot glue gun to put the spinning tops together, since it is printed in multiple parts.

Introduction

Start by explaining the pupils how the learning activity will be planned, and this can give the pupils the possibility to self-regulate.

Demonstrate how the basis spinning top works, and talk with your pupils about which abilities a good spinning top has, then talk about factors which can influence a design like this. Make groups and make sure that everyone have the basis design and can start modifying. Also explain that some parts need to stay unchanged in order to make the different parts of the design fit together.

Designing

The pupils will modify parts of the basic design, therefore they need access to that. Soon they will decide on modifying one or more parts of the design, and let them explore and discuss their options. Some pupils might want to change the diameter on their spinning top, others might want to increase its weight etc.

Appendix C

21st century skills in Denmark

The Innovative Teaching and Learning Research project have designed "21st Century Learning Design rubrics" to help teachers identify 21st century skills and the possibilities they have to include them in their teaching. They have made a complete guide over six different and important 21st skills [Microsoft, 2012]:

- Collaboration
- Knowledge construction
- Self-regulation
- Real-world problem-solving and innovation
- The use of Information and Communications Technology (ICT) for learning
- Skilled communication

These guides contain an overview of key concepts, a rubric to help teachers score on a scale from 1-4 on which level a learning activity offer the opportunities to develop a certain skill, and a flowchart that helps the teachers score pupils correctly in each case. In some cases the skills are scored on a scale from 1-5, however, 5 represents an additional higher goal. This section contains a explanation of each of the six skills and what they contribute [Microsoft, 2012].

Collaboration

When working on a project at a workplace several people often need to collaborate, often between fields, companies or even countries. However, traditional schooling does not necessarily support collaboration since the students often work alone and receive grades alone. In order to learn the skill of collaboration the pupils need to work with others, discussing issues, solving a problem, or creating a product. To reach the higher level of this rubric the the pupils need to have shared responsibility for their work and if the learning activity is structured in a what that demands that the pupils make substantive decisions together they will score 4 in the rubric. By doing that the pupils will learn the collaboration skills of: *negotiation, conflict resolution, agreement on what must be done, distribution of tasks, listening to the ideas of others, and integration of ideas into a coherent whole*. However, in collaboration it is possible to score 5, by having the pupils work interdependent which requires all the students to contribute to a common task in order to succeed. The collaboration rubric is as follows[Microsoft, 2012]:

- 1 *Students are NOT required to work together in pairs or groups.*
- 2 *Students DO work together, BUT they DO NOT have shared responsibility.*
- 3 *Students DO have shared responsibility, BUT they ARE NOT required to make substantive decisions together.*
- 4 *Students DO have shared responsibility, AND they DO make substantive decisions together about the content, process, or product of their work, BUT their work is not interdependent.*
- 5 *Students DO have shared responsibility, AND they DO make substantive decisions together about the content, process, or product of their work, AND their work is interdependent.*

Knowledge Construction

Pupils need to do more than reproduce the information they are given, skills like critical thinking and reasoning are necessary in order to success in higher academics and in knowledge based organizations. They need to evaluate and integrate the information which they find on the internet and use it productively in their work. In order to make knowledge construction the pupils can use interpretation, analysis, synthesis or evaluation in order to generate ideas or understanding which are new to them. Knowledge construction needs to be the main requirement of the learning activity in order to score 3 in the rubric. In even stronger learning activities the pupils will use the knowledge in new context and to add an additional higher level the pupils

are working on an interdisciplinary task. The rubric of Knowledge construction is as followed [Microsoft, 2012]:

- 1 *The learning activity does NOT require students to construct knowledge. Students can complete the activity by reproducing information or by using familiar procedures.*
- 2 *The learning activity DOES REQUIRE students to construct knowledge by interpreting, analysing, synthesizing, or evaluating information or ideas, BUT the activity's main requirement is NOT knowledge construction.*
- 3 *The learning activity's main requirement IS knowledge construction, BUT the learning activity does NOT require students to apply their knowledge in a new context.*
- 4 *The learning activity's main requirement IS knowledge construction, AND the learning activity DOES require students to apply their knowledge in a new context, BUT the learning activity does NOT have learning goals in more than one subject.*
- 5 *The learning activity's main requirement IS knowledge construction, AND the learning activity DOES require students to apply their knowledge in a new context, AND the knowledge construction IS interdisciplinary. The activity DOES have learning goals in more than one subject.*

Real-World Problem-Solving and Innovation

In almost any workplace problem-solving is a necessary skill, it is used to redesign products, find new ways to reach a market or how to take advantage of new materials. Successful workers know how to generate and test ideas which will solve a real-world problem. In this rubric the pupils' work needs to involve problem-solving, in higher level learning activities they use data or situations from the real world. The strongest learning activities require that the pupils find an innovative solution on the problem. Often problem solving leads to the pupils: investigating different parameters of the problem; generating ideas; exploring different possible approaches; Testing the solution; and make iterative improvements to solve the problem. Working with real world problems indicate that the pupils work with authentic situations which exist outside the academic context. Real world problems have these four characteristics: Real people are affected by the problem; the solutions benefit others than the teacher; have a specific context; The pupils use actual data produced in the real world. In order to make an innovative problem solving the solution needs to be brought to life and implanted in the world, however, if the pupils are not in a position to do this it is sufficient to present it to someone who is. The rubric for Real-World Problem-Solving and Innovation are as followed [Microsoft, 2012]:

- 1 *The learning activity's main requirement IS NOT problem-solving. Students use a previously learned answer or procedure for most of the work.*
- 2 *The learning activity's main requirement IS problem-solving, BUT the problem IS NOT a real-world problem.*
- 3 *The learning activity's main requirement IS problem-solving, AND the problem IS a real-world problem, BUT students DO NOT innovate. They are NOT required to implement their ideas in the real world, or to communicate their ideas to someone outside the academic context who can implement them.*
- 4 *The learning activity's main requirement IS problem-solving, AND the problem IS a real-world problem, AND students DO innovate. They ARE required to implement their ideas in the real world, or to communicate their ideas to someone outside the academic context who can implement them.*

Use of Information Communication Technology for Learning

Information communications technologies(ICT) are an important part of living in the modern world, and they can support a range of 21st century skills, in particular: Knowledge construction, and real-world problem-solving and innovation. Since the technology allows pupils to gain knowledge, collect data and contact people otherwise not possible. ICT is defined in this context as a wide range of available digital tools and everything from computers, smart phones and other hardware to internet browsers, multimedia development tools, social media and others software systems. By using ICT the pupils can not only consume information but also design and create new information. Pupils can make use of ICT by using technology to complete all parts of the learning activity, it is important that the pupil controls the ICT, not the teacher. This can be in situations where the pupil needs to simulate something in order to get a better understanding of something complex. The rubric for use of ICT for learning are as followed[Microsoft, 2012]:

- 1 *Students do not have the opportunity to use ICT for this learning activity.*
- 2 *Students use ICT to learn or practice basic skills or reproduce information. They are not constructing knowledge.*
- 3 *Students use ICT to support knowledge construction. BUT they could construct the same knowledge without using ICT.*
- 4 *Students use ICT to support knowledge construction, AND the ICT is required for constructing this knowledge, BUT students do NOT create an ICT product for authentic users.*

- 5 *Students use ICT to support knowledge construction, AND the ICT is required for constructing this knowledge, AND students do create an ICT product for authentic users.*

Self-Regulation

In today's world individuals need to incorporate feedback in order to develop and improve their work. For pupils to grow up to be successful workers they need to be self-regulated thinkers who can manage their own life, work and ongoing learning. Often the teacher structures the pupils' work for them, by directing them, however, they should instead work *with* them and guide the pupils to manage their own time and take responsibility. Therefore, learning activities that teach the pupils to self-regulate must be long-term, in order to let the pupil manage their own time. The most successful learning activities will provide the pupils with evaluation, before they are finished, which can help them improve their work. Self-regulation skills can be increased over time, however, in the beginning the pupils might need more explicit guidance. In order for the pupils to plan their own tasks they also need to know that the learning goals are. The rubric for self-regulation are as followed [Microsoft, 2012]:

- 1 *The learning activity is NOT long-term, OR students do NOT have both learning goals and associated success criteria in advance of completing their work.*
- 2 *The learning activity IS long-term, AND students DO have learning goals and associated success criteria in advance of completing their work, BUT students DO NOT have the opportunity to plan their own work.*
- 3 *The learning activity IS long-term, AND students DO have learning goals and associated success criteria in advance of completing their work, AND students DO have the opportunity to plan their own work, BUT students do NOT have the opportunity to revise their work based on feedback.*
- 4 *The learning activity IS long-term, AND students DO have learning goals and associated success criteria in advance of completing their work, AND students DO have the opportunity to plan their own work, AND students DO have the opportunity to revise their work based on feedback.*

Skilled Communication

With the technology of the 21st century it is possible to communicate in different ways and with fewer barriers than ever before. Communication is often seen as a part of the end product and it is important for all people despite their areas of expertise to know how to communicate their work to others. The pupils need to make extended communication, which are more than sending a simple text message. Here the focus is on activities that makes the pupils refine and communicate their ideas to the world, regardless of whether they used pod-casts, emails, performance, oral debate or another way to express themselves. If the pupils are using more than one type of communication mode or tool they are doing multi-modal communication which is a higher level on the rubric. In the next level of rubric the pupils uses evidence or examples which support their ideas and communication. Another important part of this rubric is that the pupils can communicate to a particular audience, in order to do that they must both choose media and content. The rubric for skilled communication are as followed [Microsoft, 2012]:

- 1 *Students are NOT required to produce extended or multi-modal communication.*
- 2 *Students ARE required to produce extended communication or multi-modal communication, BUT they are NOT required to provide supporting evidence OR design their work for a particular audience.*
- 3 *Students ARE required to produce extended communication or multi-modal communication, AND they ARE required to provide supporting evidence: they must explain their ideas or support a thesis with facts or examples OR, They ARE required to design their communication for a particular audience BUT not both.*
- 4 *Students ARE required to produce extended communication or multi-modal communication, AND they ARE required to provide supporting evidence, AND they ARE required to design their communication for a particular audience.*

Appendix D

Mammut - Learning Activity Platform

In the creative process two ideas were chosen, where one is the OCS. The other idea that was developed evolved into a learning activity platform dubbed Mammut. Both OCS and Mammut were presented for stakeholders at an development workshop. After having hosted the last workshop we became aware that the Danish company Systematic were already developing a platform similar to Mammut, called MoMo [Systematic]. Therefore, no further work will be made on developing the prototype of Mammut. Instead the focus was on developing and testing how the OCS could be used in a authentic context. Since most of the focus in the workshops was on developing on Mammut, we chose to remove this part of the study from the report to the Appendix.

Visual Representation of interdisciplinary Lessons

This concept sprung out of the idea of using a radar chart to indicate which topics can be learned by using a specific lesson plan. When using a 3D printer in education the teacher has the opportunity to teach interdisciplinary projects since the pupil often have to use different skills, from different topics, to design an object and solve a task [Blikstein, 2013b]. But making the lesson plans is only one aspect of the challenge. If a lesson plan requires involvement of multiple teachers, it can be challenging to implement due to issues with scheduling and preparation time. During an interview, with teachers experienced in 3D printing, it was suggested that a database with fully developed lesson plans would be a great advantage to other teachers (see 3.3.2). When

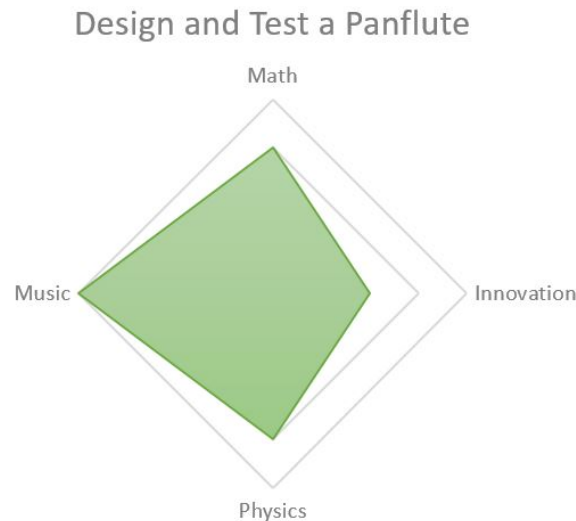

Figure D.1: An example how a lesson plan named 'Design and Teas a Planflute' and which skills the pupils will learn or use in order to complete it are visualised on a radar chard.

having this database, the teachers will get a lot of information, and this calls for a way to make it more manageable for the teachers to find the right lesson plans. The concept also includes a way to filter different lesson plans on a digital platform and make it easy for teachers to find and share them with each other. One element in this filter are to use the radar diagrams, which not only gives an indication on which topics the pupils will learn but also to which extent (see figure D.1). But there could also be other information, like ratings of a lesson plan and pictures of 3D designs. This concept can be varied in lots of ways, and a multitude of factors have to be conveyed. Therefore, the perceived complexity of the system can potentially increase. Therefore a prototype will be developed to showcase and test the concept.

Visual Representation of interdisciplinary - Initial Prototype

First the concept of making a visual representation of interdisciplinary was developed into a prototype. The prototype, are a wireframe of a platform in which the teachers could find interdisciplinary lesson plans. It was decided to call the platform 'Mammut' or "Mammoth", in order to have a quick and easy name to refer to. For the wireframing the tool Axure was used. Some initial specifications were created for the system, that were followed throughout the process of designing this prototype.

- The system should include a function that can filter the lessons after certain parameters such as grade, topic and difficulty.
- The lessons should be displayed on the home page with a short description of the les-

son, along with a radar chart showing the degree to which the topics are present within the lesson. The radar chart was chosen because it was believed that it could convey the interdisciplinarity in a helpful way.

- It should be possible to click on a lesson and see the a deeper description of a lesson on a separate page. On this page images and text should deepen the understanding of the lesson at hand.
- It should be possible to download documents that could be used for teaching the lesson. These could include, introductions and worksheets for the pupils, and guides to the lesson for the teacher.

The prototype consists of two pages: a start page where the teachers can search and get a preview of different lesson plans; and a lesson page where the teachers can find details and view pictures about a specific lesson plan, from here the teachers can also download material. Then designing the wireframe there was not developed any new lesson plans. Some of the lesson plans are from previous work, like the "Design a highway bridge" (SeeE), others are just titles made up to show examples. The colour scheme used throughout the prototype was the same used for Create it REAL's logo, and the RGB value of this was obtained. These colours were used throughout the website where they seemed appropriate. For the visual style of especially the buttons and the way they change colour when the mouse hovers over them, Create it REAL's website was used for inspiration ¹.

Prototyping the start page

The first step in creating the prototype was sketching out some initial ideas. One of the first design decisions was whether to have layout of the start page based on wide tiles in and array similar to Makers Empire². Or a design based on horizontal tiles similar to some online shops³. The horizontal tiles approach was chosen, since it seemed to best accommodate the information that was included (see figure D.2).

In the final design of the horizontal tile design, inspiration was found on online shops for clothes and electronics. It was deemed that the use of electronics web shop was somewhat similar to the use of a lesson plan finder. In both cases a user might be looking for something that sparks their interest through interesting visuals, but the user might also be looking for something very particular, and indeed simply knowing what they are not looking for. Therefore the visual style

¹<http://createitreal.com/>

²<https://www.makersempire.com/lessons>

³<https://www.komplett.dk/category/11156/pc-tablets/pc-baerbar/laptop/alle-baerbare>



Figure D.2: The horizontal tiles design which was chosen in favour of the wide tile design

of the tiles found on two electronics webshops were used as inspiration ⁴ ⁵. Similar to these online shops are the layout of the tiles was that the item furthest to the left was an image, the object to the right of that was some short text, under this text was something similar to ratings, and to the far right a button that would lead the user to a page where more information about the specific topic could be found. The layout of the surrounding menus left of and above the tiles were also inspired by the same online shops.

Finally for the front page of the wireframe, a pictogram was designed to display how hard the lesson is in terms of 3D printing technique. The pictogram used to convey this was three gears. For the beginner level only one gear would be pronounced, for intermediate two gears would be pronounced, and for expert 3 gears would be pronounced. The gear pictogram was chosen since it was believed that it would convey levels of technical challenge. In the tiles, the appropriate grade levels for the lessons was displayed using text.

Prototyping the Lesson Page

The design of the lesson page, the page the user would get to after clicking the "se mere" or "see more" button, was created in parallel with the start page. When designing both of them, the researchers continuously checked in with each other, and collaborated on the design decisions. Designs were also shared when necessary, for instance the button that would change colour when hovered over. The lesson plan included some images that was supposed to be used both for real life inspiration, but also as a guide for the teacher to know what kinds of object they could expect the pupils to create. Furthermore, a more in depth description of the lesson was provided on this page. Also, a button was added where the teacher can choose which grade level the lesson plan should be adapted to, since the same lesson with a few slight modifications, can be adapted to different grade levels. The images on this page were inspired by the ones on H&M's webshop ⁶. On this web page a smaller version of the image is used as a thumbnail, and when the thumbnail is clicked a larger version of the image is displayed. In the wireframe design the thumbnails were

⁴<http://www.pricerunner.dk/c1/2/TV>

⁵<https://www.komplett.dk/category/11156/pc-tablets/pc-baerbar/laptop/alle-baerbare>

⁶<http://www.hm.com/dk/product/64408?article=64408-A>

moved below the large image rather than to the right of it, due to the image being presented in landscape rather than portrait. Finally a button was included which, in a final version, should download the material necessary to carry out the lesson.

Workshop with CFU

After having developed the first draft of the prototypes, they were brought to consultants from CFU. CFU is an organization which guides and helps Danish schools to provide quality education.

For the meeting with CFU we organized a workshop based on practise for peer-coaching, which can be used in the stage of co-evolving when moving up the right-hand side of the U [Scharmer and Senge, 2009, p.433-434]. The original practise has 7 stages, takes 70 minutes and involves four person teams. At CFU a team of 5 consultants were available for 120 minutes, however, two prototypes needed to be presented, therefore, the practise was modified to match this conditions. Hence, The agenda for the workshop was as follows:

- **Introduction - 2 minutes:** An introduction to the workshop and practical information, including signing of consent forms.
- **Intention - 10 minutes:** This covered: which potential we see in using 3D printers as a tool for education; the purpose of today and why we need their help, what a prototype is and a presentation of our first prototype Mammut.
- **Silent reflection - 5 minutes:** A time to let the consultants reflect in silence before giving advise. After 2-3 minutes they get post-it's to write down their thoughts on the matter.
- **Group work (Mammut) - max 30 minutes:** Discussion of suggestions and advise.
- **Presentation of the Cartesian Evaluation System - 5 minutes:** The consultants are presented with the next prototype.
- **Silent reflection - 5 minutes:** A time to let the consultants reflect in silence before giving advise. After 2-3 minutes they get post-it's to write down their thoughts.
- **Group work (The Cardinal Evaluation system) - max 30 minutes:** Discussion of suggestions and advise.
- **Take away message - 5 minutes:** What new knowledge was presented and how it will influence the project and the prototypes.

The practice starts, among other things, with the consultants signing a consent form, which allow us to gather data. The gathered data are audio recording and post-its.

The main take away from the workshop with consultants from CFU is more in depth knowledge about how teachers plan their lessons and which characteristics a good support tool should have. According to CFU, The teachers are very focused on meeting the requirements in the "Curriculum goals" (in Danish: Fælles Mål). It should be added though that the opinion of the employees at CFU might be biased by the fact that one of their core tasks is to help teachers achieve these goals, and thereby they might put a high level of emphasis on this. However, funding and time are limited resources for the teachers, therefore, some teachers prefer ready to use lesson plans, if they meet the curriculum goals. The limited resources also have the impact that most teachers do not collaborate with each other on having interdisciplinary teaching, instead the schools have theme weeks where the pupils work on bigger interdisciplinary projects.

There also gave some more specific advise and suggestions, which will presented in the following.

Mammut

In general the consultants from CFU showed excitement for the lesson-plan-platform Mammut. Regarding the lesson plans it was very important that they would be based on the curriculum goals. They liked the idea and fund the design user friendly, however, they also had some concerns and suggestions on how to develop it further. The teachers, according to CFU, are very focused on reaching the common goals and therefore the lesson plans needs be a way to reach these in order to be used. Therefore it also has to be visible in the user interface which of the common goals the teachers can expect a certain lesson plan to contain. The consultants also suggested that 21st century skills and the amount of time it would take to complete a lesson should be added to the interface. Another dimension the consultants found interesting in displaying was the "openness" of the lessons, in other words how free the pupils are in the design process. The consultants mentioned that the more finished and ready the use the lesson plan are, the easier it would be to convince the teachers to use the platform and try out the lesson plans.

However, the consultants had some concerns about how to get the teachers to use the platform. First of all, how the teachers would find the platform and feel that they "belong" in there. According to CFU, the teachers already have different platforms where they can share lesson plans, but they don't do it unless they have to or at least they will not do it for free. The teachers would also have problems with getting a subscription and pay for a membership to a platform like Mammut, especially if the lesson plans are only useful for math and science teachers. The consultants believe that the beneficial way of presenting these lesson plans are as a part of a

bigger "3D printer for education" package, maybe also including the necessary hardware. When offering both the 3D printer and ready to use lesson plans the teachers would have a strong argument on why the school should buy a 3D printer. Furthermore, it would be easy for the teachers to get started with using the 3D printer, however, there would need to come new lesson plans from time to time to avoid stagnation.

The Coordinate system

When explaining this idea to the consultants at CFU, we used 3D printed bridges to show how the pupils could use the coordinate system to evaluate their designs. The bridges come from a lesson plan which we have helped a teacher six months prior. When hearing the recordings from the consultants it seemed as if some of them thought that the coordinate system was just a part of the bridge lesson plan, even though it coordinate system was supposed be a part of a lot of different lesson plans. One example is that the consultants mentioned how a real life topic like this would motivate the pupils more. Another part the consultants liked were the possibility of having the pupils re-design their objects, self-evaluating is one of the six 21st century skills which the pupils are encouraged to learn and the re-designing could be a helpful method for this. Things are moving fast in the schools, and some of the pupils just want to finish their task and move on to a new one. The coordinate system would force the pupils to slow down and evaluate their designs with a visual representation which would help them put their experience into words. Furthermore, the coordinate system could help the pupils with other of the six 21st century skills, by using it within other lesson plans. In the eyes of the participants, this tool for evaluating was somewhat unique and might offer something new. One of the consultant thought that it lacked some peer feedback where the pupils evaluated and inspired each other, another consultant suggested that a real life bridge was added on the coordinate system to set the pupils design in perspective. These ideas are both possible to carry out with the coordinate system since it has a high level of flexibility. These kinds of suggestions were quite good since they expanded the possibilities of using the system for different kinds of projects and evaluations.

However, one of the problems with the coordinate system are that it is flexibility also means that it is temporary. If the pupils need their coordinate system later in another lesson their work might be gone, since other pupils might have used it to evaluate their work. Therefore there should be a way the pupils can preserve their work for future evaluation. One suggestion is to change the format from a oilcloth to paper, or even software.

Workshop with Create it REAL

A meeting was planned with two representatives from Create it REAL, to discuss the proposed ideas and get feedback on them. The meeting was between one of the researchers, a graphical designer, and the CEO and founder of Create it REAL. We planned the workshop to be similar to the one with CFU, but with some slight alterations. It was decided to present both systems, MAMMUT and CIP, at the same time, and also to explain their connection: That you would download an interdisciplinary lessonplan from MAMMUT, and use CIP as a part of the lesson. Also presenting both at the same time would save time, as scheduling prevented the meeting from exceeding one hour. Therefore the plan for the workshop was as follows:

- **Introduction - 2 minutes:** An introduction to the workshop and practical information, including signing of consent forms.
- **Intention - 10 minutes:** This covered: Some of the findings from the project so far; how they lead to the development of the prototype; the purpose of today; and why we need their help, wa presentation of both prototypes.
- **Silent reflection - 5 minutes:** A time to let them both reflect in silence before giving advise. After 2-3 minutes they get post-it's to write down their thoughts on the matter.
- **Group work - max 40 minutes:** Discussion of suggestions and advise.
- **Take away message - 5 minutes:** What new knowledge was presented and how it will influence the project and the prototypes.

However one of the participants arrived after the first participant was given the introduction, and had silently reflected. When the late participant arrived another quick intention was given, but this participant did not get time to silently reflect, and the group work was begun immediately after the second intention briefing. The topics that were discussed, and the feedback we received will be reported below

Features

Some concrete features that could be added to both systems were suggested by the two participants. A list of these will be provided:

- An account system: It was suggested that a teacher should create an account to use the MAMMUT system, and that through that account the teacher will be able to track different information about the lessons they have used.
- Gears, to one of the participants, represented settings and not difficulty in the MAMMUT system.
- The top part of the webpage where the title and some graphics were displayed, Should be a hyperlink to the startpage.
- it was suggested to use the OCS as a 3D poster, where the pupils could display their results, and talk from that.

General feedback

Colours The graphical designer suggested that the colour palette that was used in the design of MAMMUT might not be right for the case. The colour scheme that was used was that of Create it REAL's logo, but this logo was designed to have a corporate and serious feel, and the colour scheme of MAMMUT should maybe be more "fun". However the second participant added that since it was a tool for the teachers the system should also have a certain feel of seriousness, and that it should be balanced. The website for a project called FABULOUS and LEGO's "serious play", were suggested as sources of inspiration since they also had to convey a mixture between something being fun and serious.

Possibilities for teaching The participants in general thought that the OCS system provided the possibility for pupils to learn how a complicated system is created. By slowly adding more features, and altering a product the pupils will see that complicated systems that surround them has been created in a similar manner. It was suggested that this could potentially make pupils see these systems in a different way a demystify certain complex things.

The OCS underlined the importance of not giving all the answers of theory upfront, but letting the pupils discover this for themselves and then introduce it. For instance in the example with the bridge some pupils discovered the idea of adding rafters to their design in order to create a higher level of strength. The teacher could also have introduced this concept at the beginning of the class, but according to the OCS, discovering a concept in this way could lead to the pupils "owning" the knowledge in a more deep way.

It was suggested that OCS could introduce concepts of, project management, and how to start

an engineering project. If the children are encouraged to figure out what the axis of KIP should be, then they are essentially planning what the purpose of the object is, and how best to achieve this through design and multiple iterations. Finally it was mentioned that the lessons should be balances in both the freedom given and the constraints, since a too high level of freedom might not provide the needed structure, whereas a too high level of constraint will defeat the purpose of discovering concepts of ones own accord.

Teachers attitudes The CEO talked a lot about the importance of having the teacher on board with both MAMMUT and OCS. It was mentioned that it is important for the success that teachers are comfortable with teaching the subject matter since it is very different from traditional teaching. Therefore, it was suggested to provide a diverse range of material in a way that makes it very easy to approach, and that afterwards teachers could use OCS within their own lessons. It was also mentioned that the "Dream Scenario" was to have teachers create and share their own lessons and experiences through the MAMMUT system. It was also discussed that since the lessons sometimes include topics that teachers might not be familiar with, such as construction theory, this information should be given it a simple "cheat sheet" like way. This would give the pupils the possibility to go through a somewhat free learning by doing process, but also provide the teachers with the necessary theoretical knowledge to guide the pupils process, and provide a theoretical context to the explorative learning experience.

Limitations Finally a few limitations were also mentioned with the OCS. For instance if all focus is put on optimizing for the axis, some ideas that are in fact very innovative might not be rewarded for it. For instance, in a previous session, where the OCS was not used, a group of pupils created a bridge that you could not throw stones from, inspired by news stories that described vandals throwing stones of bridges with the aim of hitting cars underneath. This bridge had a clear purpose of solving a problem, alas, not a problem initially described in the lesson. These pupils should certainly be rewarded for thinking of a problem that is present in society at the time, and solving it of their own accord. However, if the OCS was the only focus of the lesson they would most likely have created an expensive bridge because of the extra cost of material. Therefore, lessons should be thought out so there is room for these extra innovations. The problem of truly innovative solutions not being able to be assessed using traditional assessment tools is, however, also a known phenomenon throughout a variety of fields.

Also it was mentioned that the tool did not necessarily provide the possibility of rewarding the aesthetic aspect of designing. However, an idea to include this was given by the CEO. If the coordinate system was divided into four Quadrants, the x-Axis could be different styles of aesthetics. The axis could represent different opposites in design, for instant "cool" and "traditional", and the y axis could still represent strength. This would provide the possibility to make deliberate style choices, and even compare them in terms of the quality it adds to the

functionality.

Discussion

The workshop with Create it REAL seemed to provide more insights than the one with CFU, and also it seemed that the method was better suited for this meeting than the previous. The consulates from CFU had a hard time providing the right feedback, and could stick to the agenda of the workshop, these are clear indication on that this was not the right method for this workshop.

Appendix E

Previous work

This study started with conduction of different kinds of data. Including workshops, some of the interviews, observations, the data collection with the questionnaire. The collection of data was done before the official start of the Master project on the first of February. This chapter gives a overview of the different collections with the necessary details about when, what and how the data was collected. Futhermore other work related to the topic was done as part Anders' internship at Create it REAL in the fall of 2016.

Timeline of data collection

First a time line are presented to create a overview of when the data collections was made:

31/1 2017 - Kick start Workshop Day on Sonderbro Skole

17,18 & 20/1 2017 - Theme week about mobile accessories on Hals Skole

11/1 2017 - Meeting with Center of Education Aalborg (CFU)

3/1 2016 - Interview with teacher on Sonderbro skolen

13/12 2016 - Interview with teacher on Hals Skole

29/11 2016 - 3D printing with Coding Pirates

28/11 2016 - High way bridge workshop

9/11 2016 - Christmas ornaments workshop

8/11 2016 - Observation in Vadum

25/10 2016 - 3D printing with Coding Pirates

12/10 - Workshop

Workshops

Through the time of data collection four workshops was hosted. The workshops had different themes, but the purpose was to educate students about 3D printing. The workshop was used as a part of Anders intern ship at Create It REAL and as Helga project under her Creative Genius Semester. As we hosted workshops we gained experiences which is why the details of the workshops increases gradually. The questionnaire data was gathered at the last workshop the 31st of January 2017.

The first workshop

This workshop was an introduction to 3D printing for students in 4 grade. 19 students came to participate, they bought their iPad and used ABC design as design tool. This workshop started with a short idea generation where the students had to make figures out of basic shapes using paper. Afterwords the students would do the same using the design tool constructing a object ready for printing. Anders had responsibility for the 3D printers while Helga had responsibility for the paper prototyping part and acted as technical support. The data collected in this workshop was fields notes, STL files and a few pictures.

Christmas Ornament workshop

In this workshop was an introduction to 3D printing. The workshop took no longer than four hours, in that time 19 students designed at had printed a small Christmas ornament. The students used Thinkercad as design tool and brought their own Cromebooks to design on. The task Was designed by Anders and the only demand was that the you could tie a string in the ornament in order to hang it. During the workshop Anders had responsibility for getting the

designs 3D printed. Helga helped the students with the design tool, other kind of technical support and idea generation. The data collected in this workshop was field notes and STL files.

High way bridge workshop

This workshop was part of a bigger task the students had received by their teacher, the students was in 8-9 grade. The students was told to design a high way bridge where four trucks could drive under and two cars could drive over. In group of 2-3 the students would make their scaled version of their design using Thinkercad. Hereafter would they arrive to the workshop to print an test their design. Each group lend their own 3D printer with a special color of filament which made it very easy to know which group made what design. It also meant that each group had to take time into consideration since they only had 3 hours in the workshop to use the 3D printer. After having printed a bridge the students would test it's durability after which they would improve their design if they had time. A Part of the task was to calculate the price of their design and therefore the students could both make their design cheaper and/or stronger. The students was self in charge of the printing which lead that both Anders and Helga gave technical support during the workshop. The data conducted was field notes, STL files and pictures.

Kick Start Workshop

This workshop was hosted the 31/1 2017 to kick start a big assignment between four schools. The assignment are the end of a project with Aalborg municipality . The schools was each to design and 3D print 15x15 cm puzzle piece which fitted with the other schools. Each student would design a smaller part of their schools 15x15 cm puzzle piece with something that symbolised a special place to them. As an example two smaller puzzle pieces was made, one with the Eiffel tower and one with a mountain. The purpose of the workshop was to help the students in different areas of the assignment. There was 87 students signed up for the workshop, with a show of 66 students (35 boys and 29 girls). Because of the large amount of participants was the workshop was divided into four stations where the students rotate between them in smaller groups ever half hour. The four stations was as following:

- Idea Generation
- Thinker cad Tools
- Design of Connections

- Reflection

The idea generation was made to help the students to find out which special place they wanted to print. After a short introduction the students would generate ideas on their own, here stimuli would be given. They were told to find as many places as they could regardless of how much meaning it had to them or how easy it was to design and 3D print. Next the students would share their ideas to each others to inspire each other. Hereafter the ideas will be translated into items which are more easy for the kids to design and print.

Appendix F

Data Tracing Guide

This is a guide to help our reader navigate in raw data, databases, interviews guides and coded analyses. Most of the data are present in the folders, however pictures, video and recordings are omitted since they are sensitive in nature and the files are rather large. The folder structure can be seen in the list below. The items written in *italic* font are the names of files, and the items that are both ***italic and bold*** are the files that are referenced directly in the rapport, and these will be followed by a description on how to find the data that is referenced throughout the report. All the raw data is in Danish, and any quotes or field notes included in the report will be translated to the best of our abilities.

- Field Study Data
 - Observationer Sønderbro
 - * Field notes
 - *Anders Field notes*
 - *anders notes (1)*
 - *anders notes*
 - *Helga Field notes*
 - *helga notes*
 - * Video Transkriptioner when this data is referred to, it is simply referred to the , since the videos are rather short. The coding of the video can be found in the
 - *transkriptionBoats*
 - *transkriptionBridges*
 - *transkriptionFrem*
 - *transkriptionTops*

- * *concent*
- * **Database** When this data base is referenced it will be done either by referring the name of the sheet in which the data can be found, and the row number that the data can be found in. So¹ refers the 50th, 173rd and 174th Row. In cases where videos are referred to it will be done using the video number² since the videos are rather short.
- Video Review Session
 - * *Facilitator guide*
 - * **transkriptions VR** This data base is referenced by the time that is displayed in the left column in the document. So *VR Bruce Time 5:12* refers to the time 5:12 that can be found in the left column of the document.
- Idea generation
 - *Creative Process*
 - *List of ideas*
- Pilot study data
 - Interview
 - * **interview coding** This data base will be referred to by the signifier Int, and the row-numbers of the spread sheet, so³ will refer to row 35 in the spreadsheet.
 - * *interview guide til 3-1*
 - Observations
 - * Field notes fra Vadum
 - *Extended field notes from Vadum*
 - *Vadum field notes (Original)*
 - * Field notes from Hals
 - field notes - renskrivning
 - Fieldnotes (Helga)
 - hals concent
 - hals noter
 - * **Observation coding** When wanting to backtrack observations the footnote will contain the word "obs" and the row number of that data chunk⁴.
 - Questionnaires

¹Bro: 50, 173 and 174

²Video 13, 15 and 18

³Int: 35

⁴obs: 33

- * Raw data
 - *field notes*
 - *hals*
 - *hojvang*
 - *sonderbro*
 - *vadum*
- * ***Questionnaires Coded*** When wanting to backtrack questionnaire data the footnote will contain more information⁵. This footnote tells first which schools the data comes from, hereafter which page in the pdf., and last to which question.

⁵Hals 2, Q:D